

USER MANUAL

OAKWORKS® Celesta® and Clodagh Gemini



Celesta®



Clodagh Gemini

Printed in U.S.A.

All rights are reserved. No part of this document may be photocopied, reproduced or translated to another language without prior written consent of OAKWORKS®, Inc.

OAKWORKS® is a registered trademark of OAKWORKS®, Inc.

Notice

The information contained within this document is subject to change without notice and should not be construed as a commitment by OAKWORKS®, Inc.

OAKWORKS®, Inc. encourages requests for technical specifications and the like documentation to ensure accuracy. The appropriate documentation is available upon request.

OAKWORKS®, Inc. shall not be liable for incidental or consequential damages in connection with or arising out of the furnishing, performance, or use of this document and the program material which it describes.

TABLE OF CONTENTS

Important Safety Instructions	
Product Use Description.....	1
Symbol Identification	1
Important Safety Instructions.....	2-3
Product Description & Photo	
Celesta Electric Salon	4
Clodagh Gemini Electric Salon.....	5
Controls Operations - Electric Salon.....	6
Celesta Flat Top	7
Clodagh Gemini Flat Top.....	8
Controls Operations - Flat Top	9
Installation	
Grounding	10
Under Table Cabinet & In-Cabinet Power Strip.....	11
Important Safety Note	11
Directions for Use	
Levelling Instructions.....	12
Moving the Table.....	12
Removing Top Pad.....	13
Adjustable Body Comfort (ABC) System Use (Option).....	14
Integrated Heated Top (Option).....	15
QuickLock Face Rest: (Accessory Option).....	16
Arm Rest Installation and Adjustment Instructions.....	17
Cleaning & Disinfection	
Recommended Cleaners/Disinfectants	18
Cleaning Process	18
Inspections	19
Warranty Information	19
Model Number & Serial Number	
Product Label Location.....	20
Specifications	
Table Dimensions.....	21
Permissible Environmental Conditions.....	22
Electrical Specifications.....	22
Dimensions	22
Contact Information	back cover

PRODUCT USE DESCRIPTION / IMPORTANT SAFETY INSTRUCTIONS

PRODUCT USE DESCRIPTION

The product is a cord connected spa/massage table for commercial use. It is intended for indoor use. Maximum weight capacity of 500 lbs.

The product is intended to be used by trained professionals in a controlled environment. A review of the following Safety Instructions is important for the safety of the operator and client. Read all instructions and understand this entire user manual before using the product. There are no known contraindications to the use of this equipment.

The table should not be used in any other manner than that described within this manual. Use of any unnecessary force or unauthorized procedures could result in injury to practitioner, client or equipment.

SYMBOL IDENTIFICATION



This symbol, when used in this manual and on product labels, represents a caution warning. Be sure to read and comply with all precautions and warnings.



This symbol, when used in this manual and on product labels, warns against an electrical shock hazard. Be sure to observe and comply with all warnings.



This symbol, when used in this manual or on product labels, indicates a Protective Earth (Ground) Terminal.



This symbol, when used in this manual and on product labels, indicates the name and address of the manufacturer.



This symbol, when used in this manual or on product labels, indicates the country of manufacture along with date of manufacture of the device next to it.



This symbol, when used in this manual or on product labels, indicates alternating current (AC).



This symbol, when used in this manual or on product labels, indicates direct current (DC).



This symbol is used to indicate that the operator should consult the user manual.



This symbol indicates that when the end-user wishes to discard this product, it must be sent to separate collection facilities for recovery and recycling.

IMPORTANT SAFETY INSTRUCTIONS

IMPORTANT SAFETY INSTRUCTIONS



DANGER

READ AND SAVE THESE INSTRUCTIONS

To reduce risk of electric shock:

1. Always unplug this furnishing from the electrical outlet before cleaning.
2. Connect this furnishing to a properly grounded outlet only. See Grounding Instructions in this manual.

Electrical Shock Hazard - The power supply/control module is located on the lift frame. No user serviceable parts are inside. Refer servicing to qualified personnel. Unplug wall plug prior to contact with any cables connected to the power supply.



WARNING

To reduce the risk of burns, fire, electric shock or injury to persons:

1. Unplug from outlet before adding or removing parts.
2. Never operate this furnishing if it has a damaged cord or plug, if it is not working properly, if it has been dropped or damaged, or dropped into water. Contact Oakworks Customer Service before use at 717.235.6807.
3. Keep the cord away from heated surfaces.
4. Never drop or insert any object into any opening.
5. Do not use outdoors.
6. Use this furnishing only for its intended use as described in these instructions. Do not use attachments not recommended by the manufacturer.
7. To disconnect, turn all controls to the off position, then remove plug from outlet.
8. Improper connection of the equipment-grounding conductor can result in a risk of electric shock. Check with a qualified electrician if you are in doubt as to whether the product is properly grounded.
9. Do not modify the plug provided with the product - If it will not fit the outlet, have a proper outlet installed by a qualified electrician



WARNING

- Risk of Injury - 500 lbs. (227 kg.) maximum load.
- Risk of Injury - Do not operate this equipment unless properly trained.
- Close supervision is necessary when this furnishing is used by, or near children, invalids, or disabled persons.
- This unit is For Commercial Use Only and to be operated only by trained personnel.
- Lifting & Top motion electric motors are rated at 10% duty cycle max. (2 minutes on, 18 minutes off)



PINCH HAZARD

- Keep hands, feet and controls away from the table while making adjustments.
- Risk of Injury - Not to be used in locations where children or people with cognitive disabilities are anticipated to be present.
- Risk of Injury - Children should NEVER be near the table when in use.

IMPORTANT SAFETY INSTRUCTIONS



ENTRAPMENT

- Risk of Injury - The picture below indicate areas of entrapment that can occur when operating this equipment. It is the responsibility of the operator to ensure that bystanders are not in or around these areas during operation.



CAUTION

- The use of accessories, transducers, and cables other than those specified by the manufacturer, may result in increased emissions or decreased immunity of the table.
- The table should not be used adjacent to or stacked with other equipment. If adjacent or stacked use is necessary, the table should be observed to verify normal operation in the configuration in which it will be used.
- The table is designed to be a stand-alone table. This table must not be modified or incorporated into any other equipment.
- Proper operation of this equipment is very important for the safety of the operator, client, and any other individuals in the area of this equipment. Directions for use of this equipment are described in this manual. The operator should read these sections carefully.
- Weight Limit: (client and accessories) 500 lbs. (227 kg.) Do not exceed.
- Adjustable Breast Comfort (ABC) System Weight Limit: 100 lbs. (45 kg.)
- Do not sit on the ABC System. Only use the ABC System as intended. Do not place foreign objects into the ABC System. For safety of your client, use a cloth sheet between the ABC System and your client.
- Be certain that the table is completely lowered without any tilt being present prior to discharging an ambulatory client. The client may lose balance and fall.
- When lowering the table, make sure there is nothing underneath the tabletop that can impede motion (like stools, cabinets, accessory parts, cleaners, etc.) When using the table Height Up function, do not place anything between the metal frame and the base structure. Damage can occur to the table.
- Do not sit on backrest or footrest sections.
- Before moving any of the tables, disconnect the power cord from the power outlet.
- The table weighs as much as 260 lbs. (118 kg.)
- Do not lift table by the tabletop pad. This can damage the removable pad. Use extreme caution when lifting the table to move it. 4 people are required to move the table safely.
- Do not use the table to transport a client.

PRODUCT DESCRIPTION

Celesta *Electric Salon*



STANDARD SPECIFICATIONS	
Motion 1	Powered 25"-35" (63-89 cm.) Height Range
Motion 2	Powered 0-70° Backrest
Motion 3	Powered 0-30° Foot Rest
Foot Control	All powered motions
Hand Control	All powered motions
Table Voltage Options	100V/60Hz - 230V/50Hz
Table Capacity	500 lbs. (227 kg.) (client and accessories)
Widths	29" (74 cm.), 31" (79 cm.), or 33" (84 cm.)
Length	73" (185 cm.)
Padding	4" (10 cm.) or 6" (15 cm.) Aerocel Foam™
Table Weight	260 lbs. (118 kg.)

OPTIONS
Adjustable Breast Comfort (ABC) System
Wood Finishes
Integrated Heated Top
ACCESSORIES
QuickLock Face Rest
Boiance Shelf Support
Side Arm Rests

For electrical specs, see Specifications section.

PRODUCT DESCRIPTION

Clodagh Gemini

Electric Salon



STANDARD SPECIFICATIONS	
Motion 1	Powered 25"-35" (63-89 cm.) Height Range
Motion 2	Powered 0-70° Backrest
Motion 3	Powered 0-30° Foot Rest
Foot Control	All powered motions
Hand Control	All powered motions
Table Voltage Options	100V/60Hz - 230V/50Hz
Table Capacity	500 lbs. (227 kg.) (client and accessories)
Widths	29" (74 cm.), 31" (79 cm.), or 33" (84 cm.)
Length	73" (185 cm.)
Padding	4" (10 cm.) or 6" (15 cm.) Aerocel Foam™
Table Weight	260 lbs. (118 kg.)

OPTIONS
Adjustable Breast Comfort (ABC) System
Wood Finishes
Integrated Heated Top
ACCESSORIES
QuickLock Face Rest
Boiance Shelf Support
Side Arm Rests

For electrical specs, see Specifications section.

PRODUCT DESCRIPTION

CONTROL OPERATIONS - ELECTRIC SALON TABLES

CAUTION Do not sit on backrest or footrest sections. The hood area under the backrest top is not designed for storage. DO NOT use this area for holding anything. Damage can occur to the table.

The Celesta and Clodagh Gemini Electric Salon Tables offer height, backrest, footrest, and optional ABC positioning with electronic ease. Operate the foot and hand control as shown below to raise or lower the height, backrest, footrest, or optional ABC functions of the table.

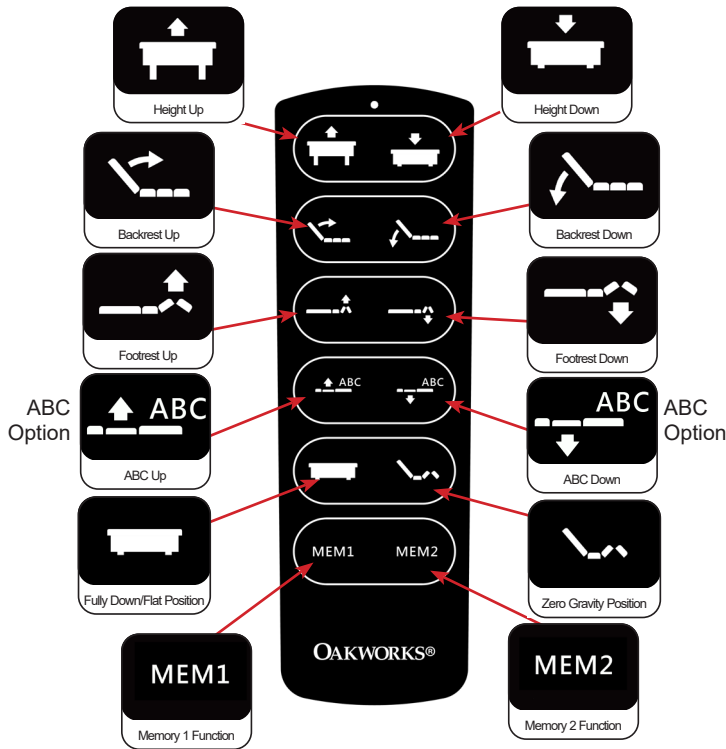

MEMORY FUNCTION USE

Use any of the top 8 buttons to orient the table in a favorite position. To store the current position in memory, press the MEM button twice (double click). Two audible beeps will confirm. To recall a stored position, press & hold the MEM button.

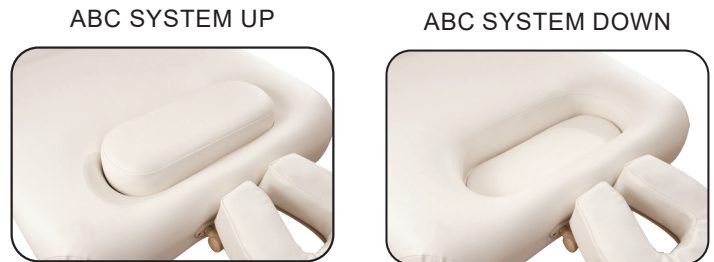

FOOT CONTROL WITH ABC

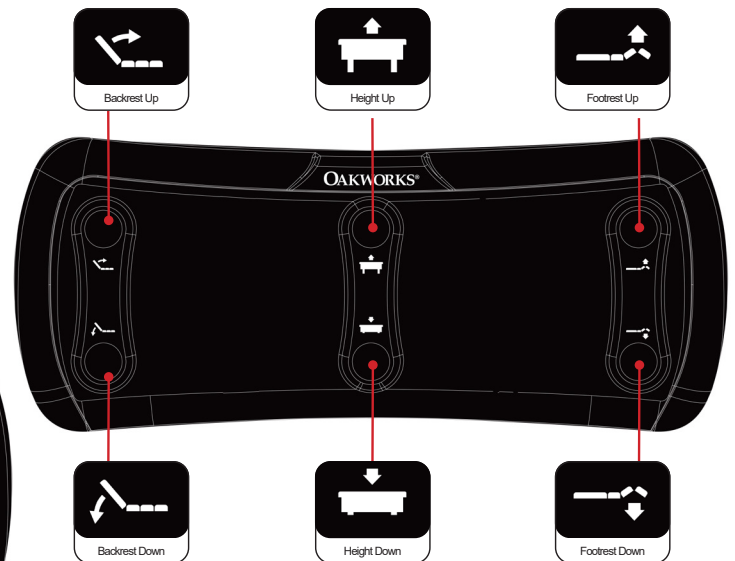
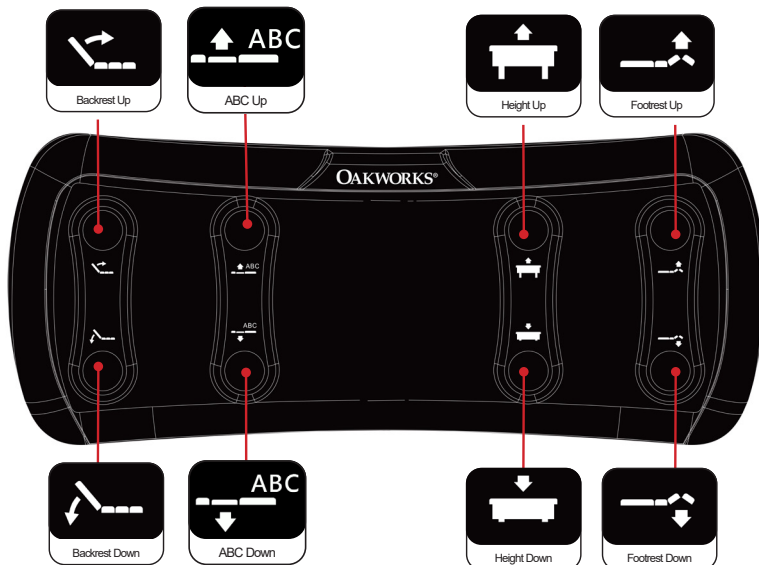

STANDARD FOOT CONTROL

PRODUCT DESCRIPTION

Celesta Flat Top



STANDARD SPECIFICATIONS	
Motion 1	Powered 25"-35" (63-89 cm.) Height Range
Foot Control	All powered motions
Hand Control	All powered motions
Table Voltage Options	100V/60Hz - 230V/50Hz
Table Capacity	500 lbs. (227 kg.) (client and accessories)
Widths	29" (74 cm.), 31" (79 cm.), or 33" (84 cm.)
Length	73" (185 cm.)
Padding	4" (10 cm.) or 6" (15 cm.) Aeroceel Foam™
Table Weight	240 lbs. (109 kg.)

OPTIONS
Adjustable Breast Comfort (ABC) System
Wood Finishes
Integrated Heated Top
ACCESSORIES
QuickLock Face Rest
Boiance Shelf Support

For electrical specs, see Specifications section.

PRODUCT DESCRIPTION

Clodagh Gemini *Flat Top*



STANDARD SPECIFICATIONS	
Motion 1	Powered 25"-35" (63-89 cm.) Height Range
Foot Control	All powered motions
Hand Control	All powered motions
Table Voltage Options	100V/60Hz - 230V/50Hz
Table Capacity	500 lbs. (227 kg.) (client and accessories)
Widths	29" (74 cm.), 31" (79 cm.), or 33" (84 cm.)
Length	73" (185 cm.)
Padding	4" (10 cm.) or 6" (15 cm.) Aerocel Foam™
Table Weight	240 lbs. (109 kg.)

OPTIONS
Adjustable Breast Comfort (ABC) System
Wood Finishes
Integrated Heated Top
ACCESSORIES
QuickLock Face Rest
Boiance Shelf Support

For electrical specs, see Specifications section.

PRODUCT DESCRIPTION

CONTROL OPERATIONS - FLAT TOP TABLES

The Celesta and Clodagh Gemini Flat Top Tables offer height and optional ABC positioning with electronic ease. Operate the foot and hand control as shown below to raise or lower the height or optional ABC functions of the table.

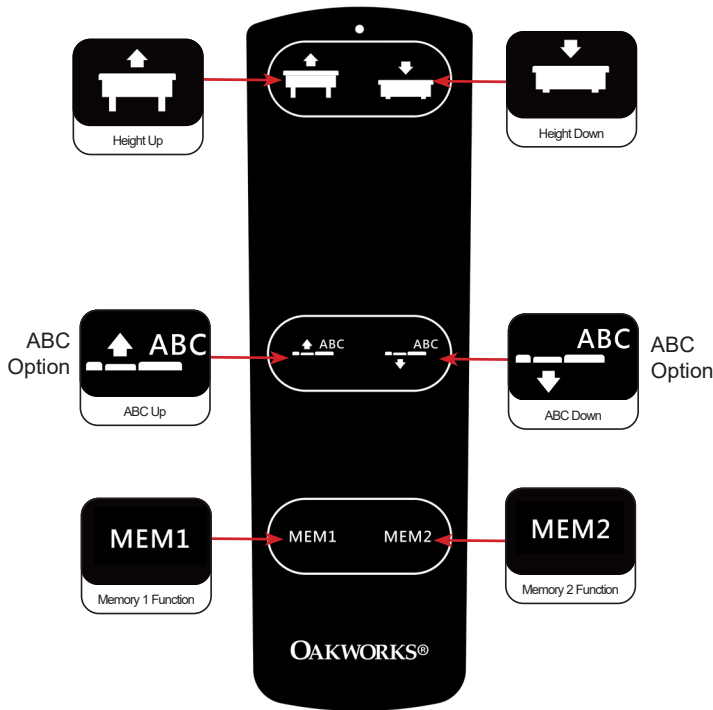

MEMORY FUNCTION USE

Use any of the top 8 buttons to orient the table in a favorite position. To store the current position in memory, press the MEM button twice (double click). Two audible beeps will confirm. To recall a stored position, press & hold the MEM button.

ABC SYSTEM UP



ABC SYSTEM DOWN



FOOT CONTROL WITH ABC

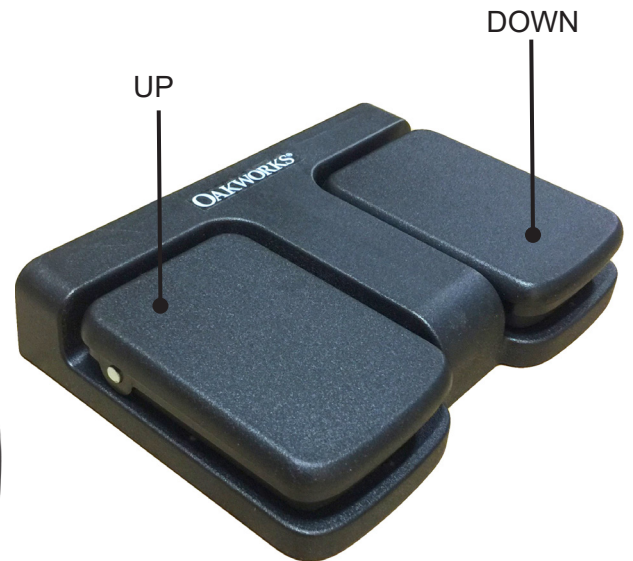
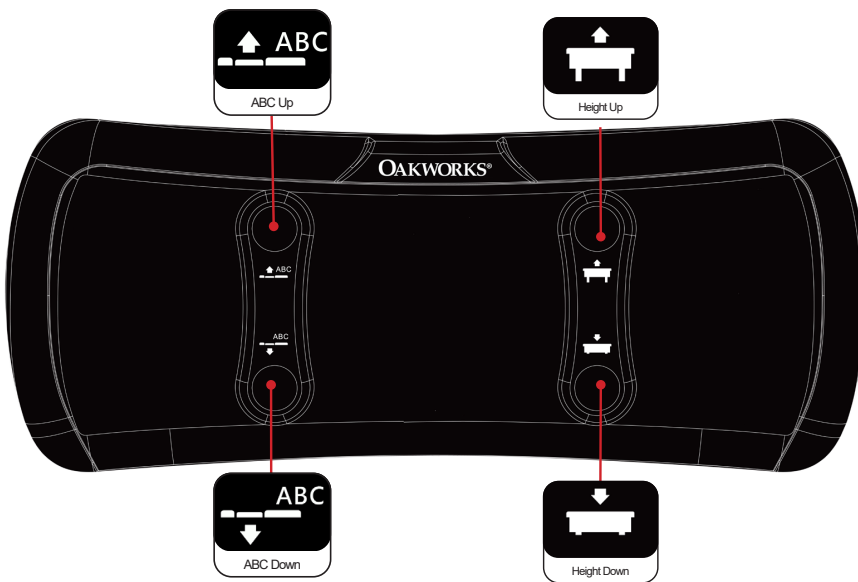

STANDARD FOOT CONTROL

INSTALLATION

The tables come completely assembled and ready to use. Plug the cord into a functioning outlet that is rated for the table. (See Grounding below)

Arrange the power cord and control cords so that they will not create a tripping hazard.

Be sure access to the plug is not blocked for disconnecting the table from power.

GROUNDING



DANGER

Risk of Electric Shock - Connect this furnishing to a properly grounded outlet only.

This product must be grounded. If it should malfunction or break down, grounding provides a path of least resistance for electrical current to reduce the risk of electric shock. This product is equipped with a cord having an equipment-grounding conductor and a grounding pin. The pin must be plugged into an appropriate outlet that is properly installed and grounded in accordance with all local codes and ordinances. See U.S. Sample below.

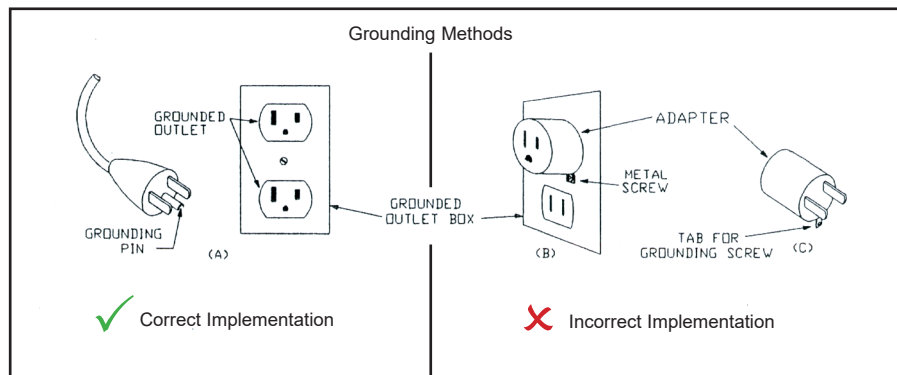

Improper connection of the equipment-grounding conductor can result in a risk of electric shock. Check with a qualified electrician or service person if you are in doubt as to whether the product is properly grounded. Do not modify the plug provided with the product - if it will not fit the outlet; have a proper outlet installed by a qualified electrician.

INSTALLATION

UNDER TABLE CABINET & IN-CABINET POWER STRIP



DANGER

This product is equipped with an interior 120-volt 60Hz power strip. The total electrical load of equipment plugged into this set of outlets is not to exceed 7 amps or 840 watts. Voltage will be different for other countries.

TO ACCESS THE STORAGE IN THE UNDER TABLE CABINET:

The large under-table cabinet provides storage for stacks of towels and other equipment. A power strip is located inside the cabinet at the head end of the table accommodates hot towel cabinets and other accessories. This allows you to store the unit inside with no excess cords to get in the way.

CELESTA MODEL

Doors slide to the side for cabinet access



CLODAGH GEMINI MODEL

Doors swing open for cabinet access

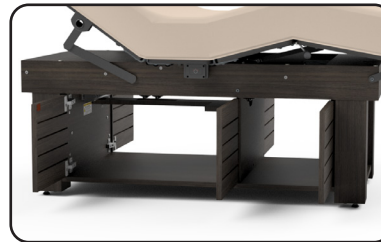

IMPORTANT SAFETY NOTE

The cabinet hood area under the backrest top is not designed for storage or as an area to hold accessories. DO NOT use this area for holding anything. Damage can occur to the table, especially when the pre-set position commands that are accessed by the hand control are activated. Placing anything on this area is prohibiting movement of the backrest and can cause damage to the table or the object. Using this area as storage will void the warranty.



NOT FOR STORAGE!

DIRECTIONS FOR USE

LEVELING INSTRUCTIONS

1. Place the table in the location where you plan to use it.
2. Rock the table to determine if it is level with the floor. If the table rocks back and forth at all, the foot that clears the floor when you rock the table will need adjustment.
3. Adjust the Leveler Foot by first loosening the locking nut found just above the rubber Leveler Foot with the 1/2" open-end wrench.
4. Lower the adjustable rubber Leveler Foot until it meets the floor snugly. Tighten the locking nut against the leg of the table with the 1/2" open-end wrench to fix the Leveler Foot in position.
5. Rock the table again to be sure adjustments have stabilized the table. If necessary make any additional adjustments in the same way.



Leveler Foot



1/2" Open-end Wrench

MOVING THE TABLE



CAUTION

Before moving the table, disconnect the power cord from the power outlet. Secure the power cord and all hand or foot controls before moving. The table weighs as much as 260 lbs. (118 kg.) Four people are required to move the table safely.



Position at lowest height



Grasp at base corner

Never lift the table by grasping the table top as the table top is not designed to hold the weight of the base and you could damage the table and the electronics that run the table top.

If you need to move the table, place one person at each corner of the table. We recommend that you have the table top in the up position (with Arm Rests removed) to have the table top ends out of the way as much as possible. Have each person firmly grasp the cabinet base at the bottom by the table legs and lift the table from the base. As when moving any piece of heavy equipment, bend at the knee and lift with your legs beneath you and not with your back. Be aware and use proper, safe procedures for moving a table of this size to prevent injury to yourself or the table. We strongly recommend that a flatbed dolly be used that can hold the entire table if moving the table involves any large distance.

DIRECTIONS FOR USE

REMOVING TOP PAD

The top pad has been designed to be easily removable and replaceable with no tools needed.

IF THE TABLE HAS A HEATED TOP:

Unplug the table from the wall outlet and disconnect the wires circled from the control box located under the platform. Pull the cables through the platform before completely removing the top pad.

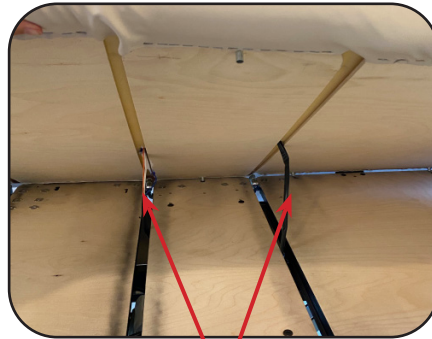
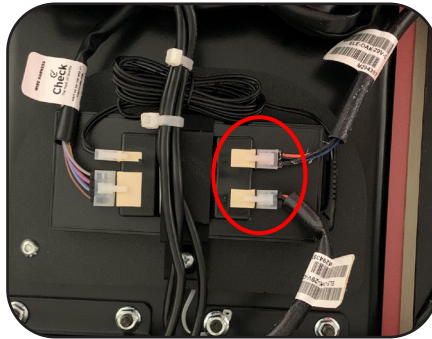

Heated Top Cables

TO REMOVE THE TOP PAD:

The top pad is attached to the platform with 8 thumb screws located below the platform as shown.



Thumb Screw Locations (4 per side)

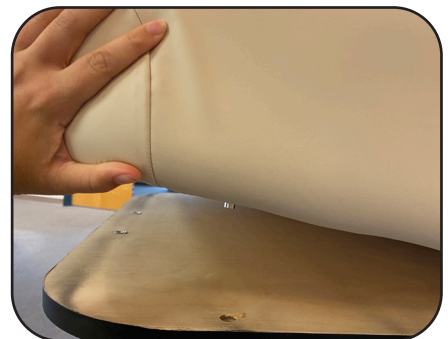

1. Unscrew the thumb screw clockwise until the thumb screw is completely removed. Repeat for all 8 thumb screws. If the thumbs screws are on too tight, a 3/16" bit can be used.

2. Lift top pad off the platform.

DIRECTIONS FOR USE

ADJUSTABLE BREAST COMFORT (ABC) SYSTEM (OPTION)



CAUTION

- ABC System Weight Limit - 100 lbs. (45 kg.) Do not sit on the ABC System.
- Do not place foreign objects into the ABC System. Only use as intended.
- For safety of your client, use a cloth sheet between the ABC System and your client.

The Oakworks Adjustable Breast Comfort (ABC) System is designed to lower the pressure on breasts and pectoral muscles, allowing the client to relax and create a more comfortable position for their spine. The height of the cushion is easily adjusted up and down in small increments by using the hand control. We recommend that the cushion height be adjusted in the following ways:

****Always start with the cushion top level with the top of the table for Prone or Supine Positioning****



PRONE POSITIONING

In Prone positions, for male or female clients when the face rest is in use, lower the cushion approximately 3/4" at a time (This is approximately 1 second of lowering) and check in with the client regarding their comfort after making the change. Incrementally lower the cushion until the client reports they are comfortable. Sometimes going back up a little will be preferred. This whole process takes no more than 15-20 seconds. After lowering, check headrest position to ensure comfort & support. *NOTE: Breast size is not the only determinate of cushion location. Every person's comfort spot is different, regardless of breast size.*



SUPINE POSITIONING

When turning clients over in the supine position, you may use the cushion to level during or after their change of position. IT is not important that the cushion be completely level. As in prone positions, make small changes in height and check in with the client.



HEAD REST USE IN SUPINE

If you are using the head rest in the Supine position, you may use the cushion at relatively high heights to facilitate stretching for short periods of time. It is not recommended that clients experience this position for more than a few minutes.

DIRECTIONS FOR USE

INTEGRATED HEATED TOP (OPTION)

USING THE INTEGRATED HEATED TOP:

The table comes with the option for a fully integrated four section heated top pad. We recommend the use of a sheet or blanket on the client to achieve an evenly distributed heating effect. Simply press the heating indicator located on the right side of the table to the desired heat level. The heat can reach up to 43°C (110°F). The system comes equipped with an 8-hour automatic shutoff.

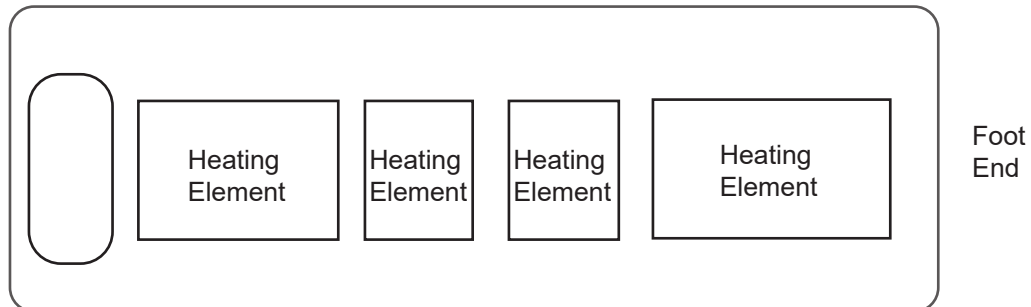
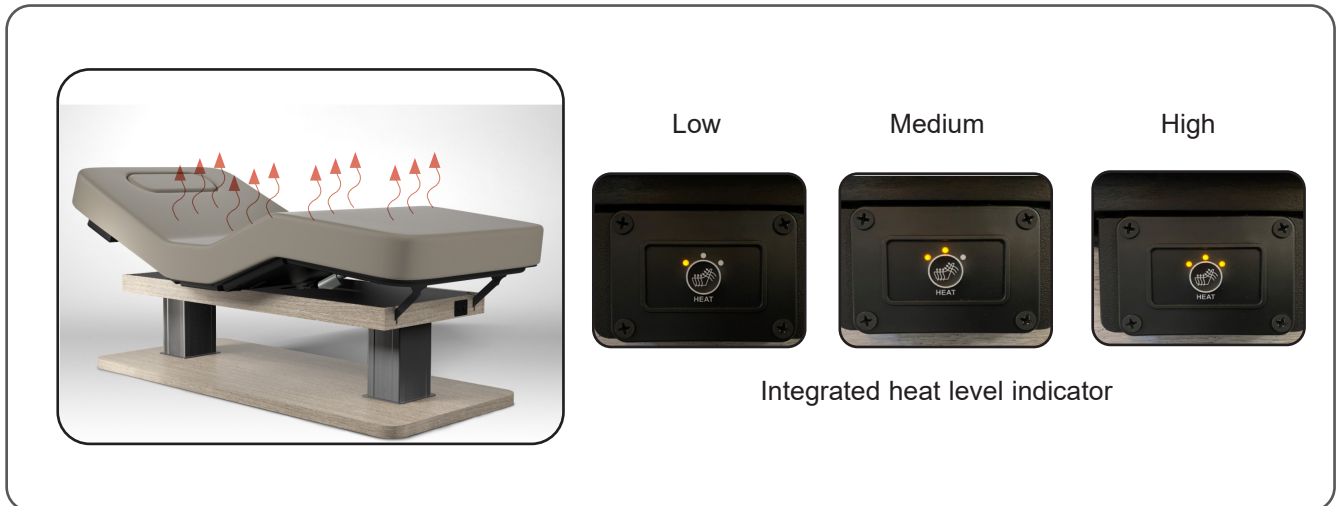

Heating Element Locations in the Pad.

BLINKING LIGHTS

If the controller's heat level indicator lights are blinking, there are two different light patterns.

Two blinking lights: An intermittent connection in the heating circuit or the temperature sensing circuit could be faulty. Unplug the table and locate the control box on the underside of the tabletop. Disconnect the heating element connectors from the control box and reconnect. Plug the power cord back into the wall outlet.

Three blinking lights: This could indicate a poor power connection in the harnessing or could be inside the heating element.

The heating system "remembers" the fault and shuts down as a result. When unplugging power, the systems will "fix" it because the system cannot remember the fault when it is no longer powered. But the fault will return if it is a hard fault that is not resolved. Call the Technical Service line 717.235.6807 if the problem continues.

DIRECTIONS FOR USE

QUICKLOCK FACE REST: (ACCESSORY OPTION)



CAUTION

- QuickLock Face Rest Weight Limit - 25 lbs (11.3 kg)
- Do not put excessive weight or pressure on the Face Rest.
- Excessive pressure can cause premature failure of the Face Rest.

Double articulating action provides nearly limitless positioning options with the QuickLock Face Rest. The adjustable pad takes pressure off sensitive facial areas while providing superb support. The QuickLock Face Rest can be used in both prone and supine positioning and folds out of the way when not in use. Adjustments are made easily by loosening the cam locks, adjusting for height and angle and then locking locks into that position. The table has a bracket at the head of the table for a variety of uses.



ATTACHING QUICKLOCK FACE REST:

When attaching the QuickLock Face Rest, slide the frame dowels into the bracket until bullet catches are snapped into place.

To remove the QuickLock Face Rest, gently pull the headrest by the dowels until it comes free. Set it safely aside or store it inside the under-table cabinet until needed.

To remove

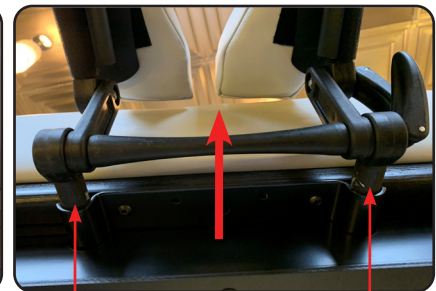

Pull by dowels

Pull by dowels

TIPS FOR GREAT POSITIONING USING THE QUICKLOCK FACE REST:

To use the face rest with your clients supine, rotate the face rest pad so that the thick part of the pad supports your client's cervical region. Adjusting the height and angle of the face rest gives your clients perfectly comfortable support.

The face pad is flexible so that you can bring the open ends together or spread them apart to achieve the most comfortable support for any size face. To avoid your client's chin from hitting the spacebar, make sure the pad is narrow enough to support their whole face.

For appropriate cervical flexion, use the cam locks to adjust the downward angle of the face rest, making sure that the surface of the face rest pad at the chin is not lower than the surface of the table.

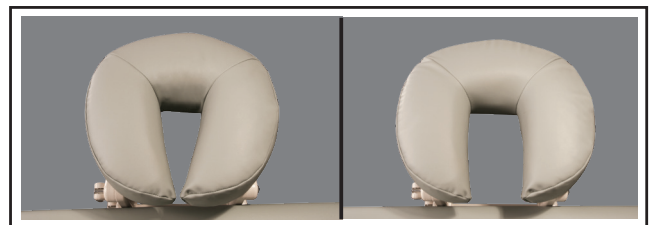

DIRECTIONS FOR USE

ADJUSTABLE SIDE ARM RESTS (ACCESSORY OPTION - SALON ONLY)



CAUTION

- Do not use the arm rest for client support during the mounting or dismounting of the chair.
- The arm rest is not designed to support the client's weight.

TO INSTALL THE ARM RESTS:

The Arm Rests adjust automatically as the back rest moves to remain parallel to the floor.



1. Insert end of arm rest into backrest hole while holding the arm rest at a 60° angle to the backrest.
2. Push end all the way into the hole and drop the arm rest into the horizontal position. Pull outward to make sure the arm rest is secure.

TO LEVEL THE ARM RESTS:

The Arm Rest height is adjusted at the factory for each table. If the armrest starts to sag with repeated use, follow the steps below to readjust.

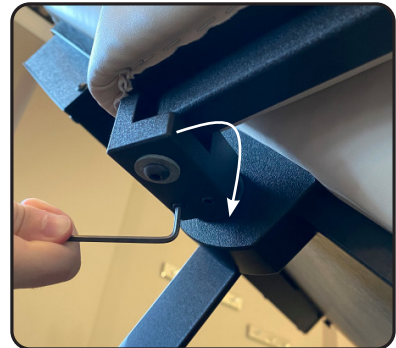
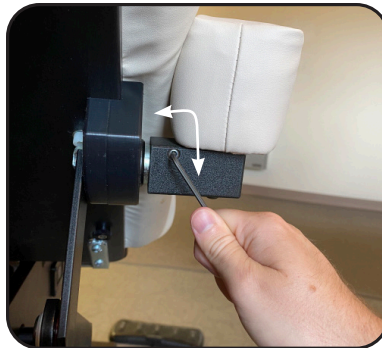
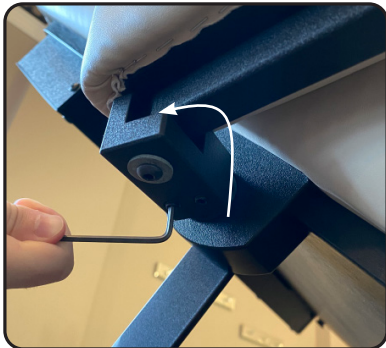

1. Loosen the bottom 2 set screws.
2. Turn the side set screw (clockwise to raise or counter-clockwise to lower) while adjusting the arm rest. Lift the arm rest slightly when doing this adjustment to reduce the weight.
3. Tighten the two bottom set screws to lock the position.

CLEANING & DISINFECTION

RECOMMENDED CLEANERS/DISINFECTANTS



DANGER

To reduce the risk of electric shock:

- Always unplug this furnishing from the electrical outlet before cleaning.

Reference the Recommended Cleaners and Disinfectant list (MMINML0008-EN) that came with the table. This information can also be found at www.shop.spatables.com under product information.

All cleaners and disinfectants have the ability to degrade the upholstery to some extent. However, following the recommended cleaner and disinfectant list and cleaning process will provide the best care for your table and support a long product life.

Oakworks recommends a prepackaged wipe for cleaners/disinfectants to ensure best distribution of disinfectant for the required kill time, without leaving excess residue and/or overexposing components therefore minimizing the potential for damage to materials. Please read and follow disinfectants manufacturers' directions for cleaning and disinfection.

Oakworks does NOT recommend the use of cleaners/disinfectants containing Hydrogen Peroxide, Acetic Acid, or Phenolics. These chemicals can cause damage to the appearance and/or material integrity of various components. Also, while the recommended cleaners/disinfectants list includes products containing Quaternary Ammonium compounds ("quats"), not all products containing quats are approved for use. Some contain additional detergents and/or surfactants which can damage some materials.

Use of non-approved cleaners or disinfectants may lead to damage to upholstery and other materials found on the table and will void the warranty.

CLEANING PROCESS

Follow the cleaners/disinfectant manufacturers' directions for use. Please note that cleaning and disinfecting an Oakworks table is a two part process. First it must be cleaned of any visible soil, then it can be disinfected. Oakworks recommends that the table be positioned in the flat position during the cleaning process. Please follow this procedure for best results:

1. Using an approved cleaner or mild liquid soap and water, clean any visible soil off of the table, working from the top to the bottom of the table. It is recommended that the upholstery be cleaned at least once a week to prevent disinfectant build up.
2. Rinse with clean water and dry with a clean cloth or towel.
3. Using an approved disinfectant, thoroughly disinfect all surfaces of the tabletop and any high-contact areas such as handles, handsets, etc., making sure they remain wet for the disinfectant manufacturer's recommended contact time. Do not allow disinfectant to pool on the upholstery after the recommended contact time.
4. Wipe off any excess liquid with a cloth or towel and clean water.
5. Dry all surfaces with a clean cloth or towel.

Avoid using writing instruments or other similar instruments around the upholstery as it can cause permanent staining. If this does occur, do not wipe with an alcohol based cleaner. Instead, blot the stain with a clean cloth/ paper towel. Use a recommended cleaner or disinfectant to remove the stain. Follow this with a rinse of clean water.

INSPECTIONS / WARRANTY

INSPECTIONS

RECOMMENDED REGULAR INSPECTIONS (monthly or local standard)

- Check for damage to the power, hand control(s) and foot control(s) on all cables.
- Visually inspect components for obvious damage that could cause problems during operation.
- If the table is creaking/ squeaking during movement of the electric salon top, apply a small amount of lithium grease to the linkages and bushings indicated below. Be sure to wipe off any excess grease.

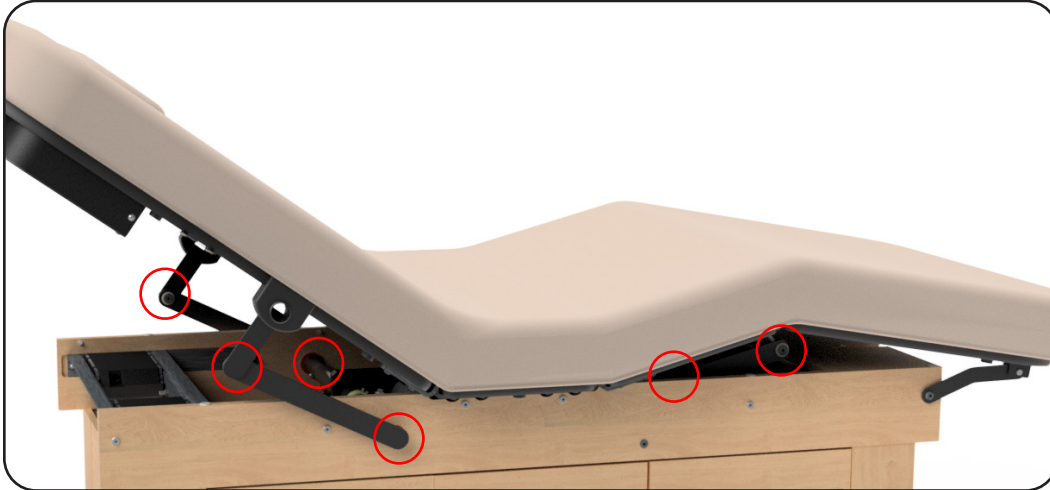

RECOMMENDED PERIODIC INSPECTIONS (yearly or local standard)

- Check for damage to the power, hands control and foot control cables and all visible wiring.
- Visually inspect components for obvious damage that could cause problems during operation.
- Check all mechanical functions using the hand control. Repeat using the foot control. Check for abnormal noises.
- Check that all fasteners are present and fastened securely.
- Check table grounding.
- Clean unusual buildup of dirt on the table and/or parts of the table not normally cleaned on a regular basis.
- Check for tears or cracks in the upholstery.

WARRANTY

View complete warranty details at www.shop.spatables.com under the Information tab "Warranty and Return Policy".

MODEL NUMBER & SERIAL NUMBER

PRODUCT LABEL LOCATION



The model number and serial number are located on the underside of the foot section.

Model Number

Serial Number

Clodagh Gemini, Celesta and Prema[®]



16796025 GNSX4EX1T411USXX Ser#:GMC563146
 Clodagh Gem E-Salon 31 x 25-37 x 72 ACTTVFN6TT
 TTPewter 01/01/2021 Order#:654321
 Notes: Sample Product Label

120V~ 60Hz
12.0 Amps Max

 CONFORMS TO:
UL STD 962
Certified to
CAN/CSA STD
C22.2 No. 68-09

Intertek
3034177

220/230V~ 50Hz
6.3 Amps Max

EC REP 

EMERGO EUROPE
Westervoortsedijk 60
6827 AT Arnhem, The Netherlands

 **OAKWORKS[®], Inc.**
923 East Wellspring Rd.
New Freedom, PA 17349 USA
Phone: 717-235-6807
www.oakworks.com

made in the USA
with US & imported parts





Duty Cycle:
MAX 2 minutes ON
18 minutes OFF

100V~ 50-60Hz
12.0 Amps Max 

デューティサイクル
最大2分オン 18分オフ

Part No. CN70537-16 - Rev. 4

Model Numbers and Serial Numbers always start with a letter.

TABLE DIMENSIONS

CELESTA TABLE DIMENSIONS

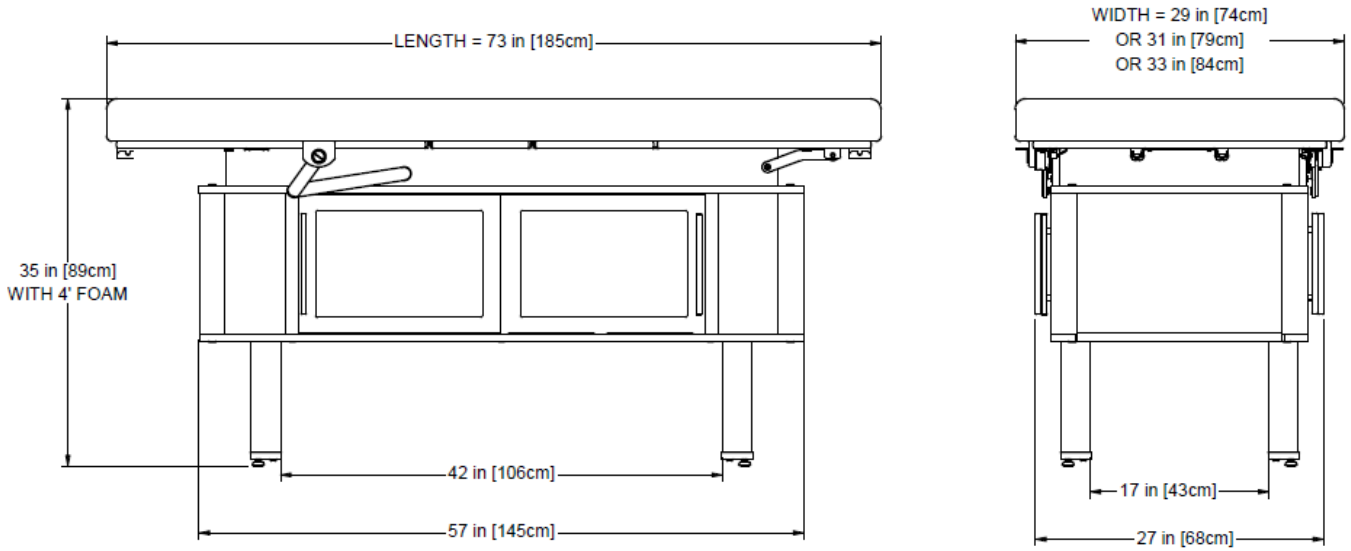

CLODAGH GEMINI TABLE DIMENSIONS

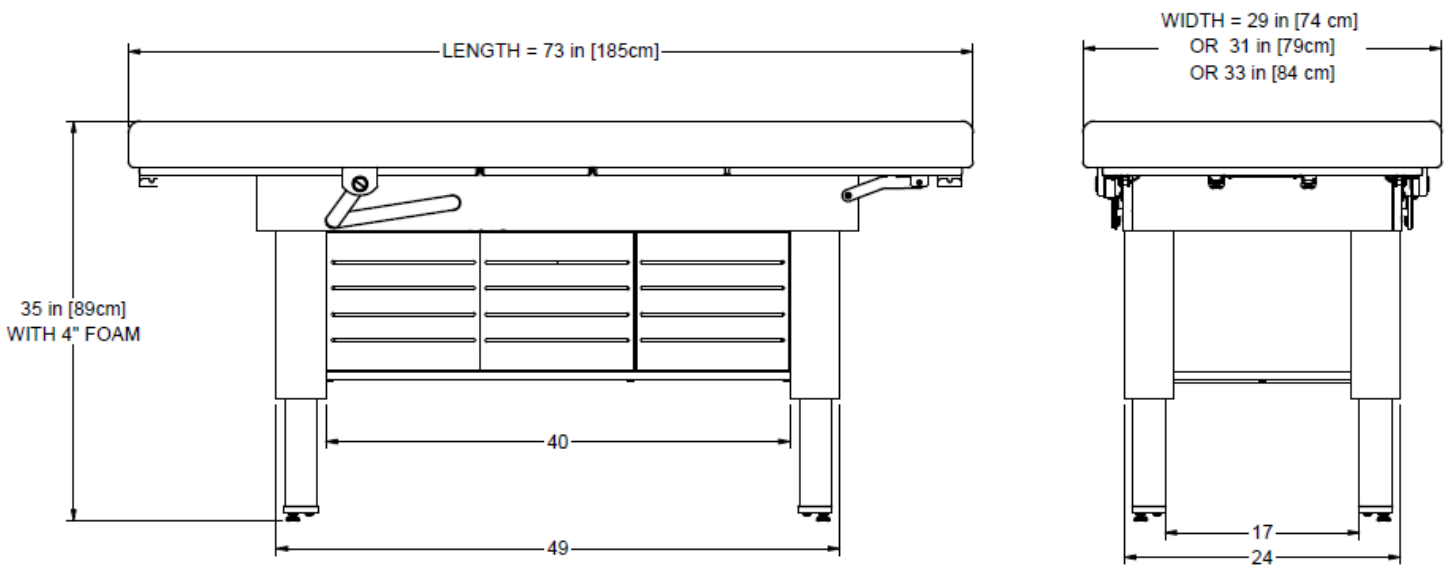

SPECIFICATIONS

PERMISSIBLE ENVIRONMENT CONDITIONS

Conditions	Temperature	Humidity	Atomic Pressure
Normal Use	50° (10°C) to 104° (40°C)	20% to 60% RH	98 to 105 kPa
Storage & Transport	-20° (-29°C) to 135° (57°C)	20% to 95% RH	98 to 105 kPa

ELECTRICAL SPECIFICATIONS

Designed for:	North America	Europe	Japan
Input Service	120V~ 60Hz, 12.0 Amps	220V~ 60Hz, 8.3 Amps	100V~ 50-60Hz, 12.0 Amps
Electric Shock Protection	Class I Equipment		
Mode of Operation	10% Duty Cycle; MAX 2 minutes ON / 18 minutes off		

CLODAGH GEMINI CABINET DIMENSIONS

Total Outside Dimensions:	40.1" L x 23.8" W x 12.3" H	101.9 cm L x 60.5 cm W x 31.2 cm H
Storage Area 1 / Head End:	25.3" L x 23.8" W x 9.3" H	64.3 cm L x 60.5 cm W x 23.6 cm H
Storage Area 2 / Foot End:	12.7" L x 23.8" W x 15.3" H	32.3 cm L x 60.5 cm W x 15.3 cm H
Opening Dimensions: Storage Area 1 / Head End:	24.8" L x 12.3" H	63.0 cm L x 31.2 cm H
Opening Dimensions: Storage Area 2 / Foot End:	12.5" L x 12.3" H	31.8 cm L x 31.2 cm H

CELESTA CABINET DIMENSIONS

Total Outside Dimensions:	38.3" L x 22.2" W x 13.3" H	97.3 cm L x 56.4 cm W x 33.8 cm H
Storage Area 1 / Head End:	18.9" L x 22.2" W x 11.0" H	48.0 cm L x 56.4 cm W x 27.9 cm H
Storage Area 2 / Foot End:	18.9" L x 22.2" W x 11.0" H	48.0 cm L x 56.4 cm W x 27.9 cm H
Opening Dimensions: Storage Area 1 / Head End:	18.5" L x 13.3" H	47.0 cm L x 33.8 cm H
Opening Dimensions: Storage Area 2 / Foot End:	18.5" L x 13.3" H	47.0 cm L x 33.8 cm H

USER MANUAL

OAKWORKS® Celesta® and Clodagh Gemini

CONTACT INFORMATION:



OAKWORKS® Inc.

923 East Wellspring Road
New Freedom, PA 17349

Phone: 717.235.6807

FAX: 717.235.6798

www.oakworks.com



Emergo Europe
Westervoortsedijk 60
6827 AT Arnhem
The Netherlands



Intertek

3034177

CONFORMS TO:

UL STD 962

Certified to CAN/CSA STD C22.2 #68



Original Instructions

Manual Part Number: SPA-RA-PM-159

Revision Level: 9

Revision Date: 03/20/2024

English, Printed in USA



OAKWORKS® Spa