

USER MANUAL

OAKWORKS®

Clinician Hydraulic



Clinician Electric
Hydraulic



Clinician Manual
Hydraulic

www.oakworks.com · 717.235.6807



OAKWORKS® Spa

Printed in U.S.A.

All rights are reserved. No part of this document may be photocopied, reproduced or translated to another language without prior written consent of OAKWORKS®, Inc.

OAKWORKS® is a registered trademark of OAKWORKS®, Inc.

Notice

The information contained within this document is subject to change without notice and should not be construed as a commitment by OAKWORKS®, Inc.

OAKWORKS®, Inc. encourages requests for technical specifications and the like documentation to ensure accuracy. The appropriate documentation is available upon request.

OAKWORKS®, Inc. shall not be liable for incidental or consequential damages in connection with or arising out of the furnishing, performance, or use of this document and the program material which it describes.

TABLE OF CONTENTS

Product Use Description.....	1
Important Safety Instructions	
Symbol Identification	1
Safety Instructions	2-3
Installation	
Grounding.....	4
Product Description & Photo	
Clinician Electric-Hydraulic	
Lift-Assist Salon	5
Control Operation - Lift-Assist Salon	6
Lift-Assist Backrest	7
Control Operation - Lift-Assist Backrest	8
Flat Top.....	9
Control Operation - Flat Top.....	10
Clinician Manual-Hydraulic	
Lift-Assist Salon	11
Lift-Assist Backrest	12
Flat Top.....	13
Directions for Use	
Hydraulic Daily Cycling.....	14
Manual-Hydraulic Height Adjustment	14
Lift-Assist Backrest Adjustment.....	15
Lift-Assist Leg Rest Adjustment	15
Moving the Table	16
Leveling the Table	16
Removing Top Pad.....	17
Adjustable Breast Comfort (ABC) System (Option)	18
Integrated Heated Top (Option)	19
QuickLock Face Rest (Accessory Option)	20
Adjustable Side Arm Rests (Accessory Option - Salon Only).....	21
Boiance Shelf Support (Accessory Option).....	22
Cleaning & Disinfection	
Recommended Cleaners/Disinfectants	23
Cleaning Process	23
Inspections & Maintenance	24
Warranty Information.....	24
Model Number & Serial Number	25
Specifications	
Table Dimensions.....	26
Cabinet Dimensions	26
Environmental Conditions.....	26
Electrical Specifications.....	26
Contact Information	back cover

PRODUCT USE DESCRIPTION / IMPORTANT SAFETY INSTRUCTIONS

PRODUCT USE DESCRIPTION

Oakworks Clinician Electric-Hydraulic and Manual-Hydraulic Series offer a variety of positioning capabilities for massage therapists and spa professionals of all specialties. On these multifunctional professional tables the practitioner can perform numerous protocols with ease and comfort. The Clinician Electric-Hydraulic and Manual-Hydraulic Series are especially effective when professional protocols require specific positioning for the client. While the client receives comfortable, relaxing support, the comfort level of the therapeutic professional is enhanced by superior ergonomics.

It is intended to be operated by Massage Therapists in a professional environment. No special training is required but a review of the following Safety Instructions is important for the safety of the operator and client. The massage professional should read and understand this entire manual before use with a client. There are no known contraindications to the use of this equipment.

The Clinician Electric-Hydraulic and Manual-Hydraulic Series should not be used in any other manner than that described within this manual. Use of any unnecessary force or unauthorized procedures could result in injury to practitioner, client or equipment.

SYMBOL IDENTIFICATION



This symbol, when used in this manual and on product labels, represents a caution warning. Be sure to read and comply with all precautions and warnings.



This symbol, when used in this manual and on product labels, warns against an electrical shock hazard. Be sure to observe and comply with all warnings.



This symbol, when used in this manual or on product labels, indicates a Protective Earth (Ground) Terminal.



This symbol, when used in this manual and on product labels, indicates the name and address of the manufacturer.



This symbol, when used in this manual or on product labels, indicates the country of manufacture along with date of manufacture of the device next to it.



This symbol, when used in this manual or on product labels, indicates alternating current (AC).



This symbol, when used in this manual or on product labels, indicates direct current (DC).



This symbol is used to indicate that the operator should consult the user manual.

IMPORTANT SAFETY INSTRUCTIONS

IMPORTANT SAFETY INSTRUCTIONS



DANGER

READ AND SAVE THESE INSTRUCTIONS

To reduce risk of electric shock:

1. Always unplug this furnishing from the electrical outlet before cleaning.
2. Connect this furnishing to a properly grounded outlet only. See Grounding Instructions in this manual.

Electrical Shock Hazard - The power supply/control module is located on the lift frame. No user serviceable parts are inside. Refer servicing to qualified personnel. Unplug wall plug prior to contact with any cables connected to the power supply.



WARNING

To reduce the risk of burns, fire, electric shock or injury to persons:

1. Unplug from outlet before adding or removing parts.
2. Never operate this furnishing if it has a damaged cord or plug, if it is not working properly, if it has been dropped or damaged, or dropped into water. Contact Oakworks Customer Service before use at 717.235.6807.
3. Keep the cord away from heated surfaces.
4. Never drop or insert any object into any opening.
5. Do not use outdoors.
6. Use this furnishing only for its intended use as described in these instructions. Do not use attachments not recommended by the manufacturer.
7. To disconnect, turn all controls to the off position, then remove plug from outlet.
8. Improper connection of the equipment-grounding conductor can result in a risk of electric shock. Check with a qualified electrician if you are in doubt as to whether the product is properly grounded.
9. Do not modify the plug provided with the product - If it will not fit the outlet, have a proper outlet installed by a qualified electrician



WARNING

- Risk of Injury - 500 lbs. (227 kg.) maximum load.
- Risk of Injury - Do not operate this equipment unless properly trained.
- Close supervision is necessary when this furnishing is used by, or near children, invalids, or disabled persons.
- This unit is For Commercial Use Only and to be operated only by trained personnel.
- Lifting & Top motion electric motors are rated at 10% duty cycle max. (2 minutes on, 18 minutes off)



PINCH HAZARD

- Keep hands, feet and controls away from the table while making adjustments.
- Risk of Injury - Not to be used in locations where children or people with cognitive disabilities are anticipated to be present.
- Risk of Injury - Children should NEVER be near the table when in use.

IMPORTANT SAFETY INSTRUCTIONS



ENTRAPMENT

- Risk of Injury - The picture below indicate areas of entrapment that can occur when operating this equipment. It is the responsibility of the operator to ensure that bystanders are not in or around these areas during operation.



CAUTION

- The use of accessories, transducers, and cables other than those specified by the manufacturer, may result in increased emissions or decreased immunity of the table.
- The table should not be used adjacent to or stacked with other equipment. If adjacent or stacked use is necessary, the table should be observed to verify normal operation in the configuration in which it will be used.
- The table is designed to be a stand-alone table. This table must not be modified or incorporated into any other equipment.
- Proper operation of this equipment is very important for the safety of the operator, client, and any other individuals in the area of this equipment. Directions for use of this equipment are described in this manual. The operator should read these sections carefully.
- Weight Limit: (client and accessories) 500 lbs. (227 kg.) Do not exceed.
- Adjustable Breast Comfort (ABC) System Weight Limit: 100 lbs. (45 kg.)
- Do not sit on the ABC System. Only use the ABC System as intended. Do not place foreign objects into the ABC System. For safety of your client, use a cloth sheet between the ABC System and your client.
- Be certain that the table is completely lowered without any tilt being present prior to discharging an ambulatory client. The client may lose balance and fall.
- When lowering the table, make sure there is nothing underneath the tabletop that can impede motion (like stools, cabinets, accessory parts, cleaners, etc.) When using the table Height Up function, do not place anything between the metal frame and the base structure. Damage can occur to the table.
- Do not sit on backrest or footrest sections.
- Before moving any of the tables, disconnect the power cord from the power outlet.
- The table weighs as much as 155 lbs. (70 kg.)
- Do not lift table by the tabletop pad. This can damage the removable pad. Use extreme caution when lifting the table to move it. 4 people are required to move the table safely.
- Do not use the table to transport a client.

INSTALLATION

All tables come completely assembled and ready to use. Plug the cord into a functioning outlet that is rated for the table. (See Grounding below)

Arrange the power cord and control cords so that they will not create a tripping hazard and where the controls are located to your liking and are conveniently accessible.

Be sure access to plug is not blocked for disconnecting the table from power.

GROUNDING



DANGER

Risk of Electric Shock - Connect this furnishing to a properly grounded outlet only.

This product must be grounded. If it should malfunction or break down, grounding provides a path of least resistance for electrical current to reduce the risk of electric shock. This product is equipped with a cord having an equipment-grounding conductor and a grounding pin. The pin must be plugged into an appropriate outlet that is properly installed and grounded in accordance with all local codes and ordinances. See U.S. sample below.

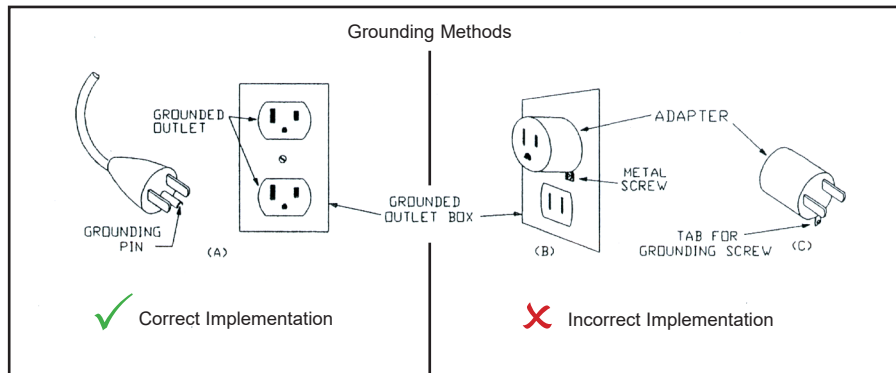

Improper connection of the equipment-grounding conductor can result in a risk of electric shock. Check with a qualified electrician or service person if you are in doubt as to whether the product is properly grounded. Do not modify the plug provided with the product - if it will not fit the outlet; have a proper outlet installed by a qualified electrician.

PRODUCT DESCRIPTION

Clinician Electric-Hydraulic Lift-Assist Salon



STANDARD SPECIFICATIONS	
Motion 1	Powered 26"-36" (66-91 cm.) Height Range
Motion 2	Manual 0-80° Backrest
Motion 3	Manual 0-30° Leg Rest
Foot Control	Height Range
Table Voltage Options	120V/60Hz - 230V/50Hz
Table Capacity	500 lbs. (227 kg.) (client and accessories)
Widths	29" (74 cm.), 31" (79 cm.), or 33" (84 cm.)
Length	73" (185 cm.)
Padding	4" (10 cm.) or 6" (15 cm.) Aerocel Foam™
Table Weight*	155 lbs. (70 kg)

OPTIONS
Adjustable Breast Comfort (ABC) System
Wood Finishes
Storage Cabinet w/Sliding Doors
Hand Control
Integrated Heated Top
ACCESSORIES
QuickLock Face Rest
Boiance Shelf Support
Side Arm Rests

For electrical specs, see Specifications section.

PRODUCT DESCRIPTION

CONTROL OPERATIONS - LIFT ASSIST SALON

CAUTION Do not sit on backrest or footrest section. The hood area under the backrest top is not designed for storage. DO NOT use this area for holding anything. Damage can occur to the table.

The Clinician Electric-Hydraulic Lift-Assist Salon Tables offer height and optional ABC positioning with electronic ease. Operate the foot control and/or optional hand control as shown below to raise or lower the height or optional ABC function of the table.

FOOT CONTROL WITH ABC

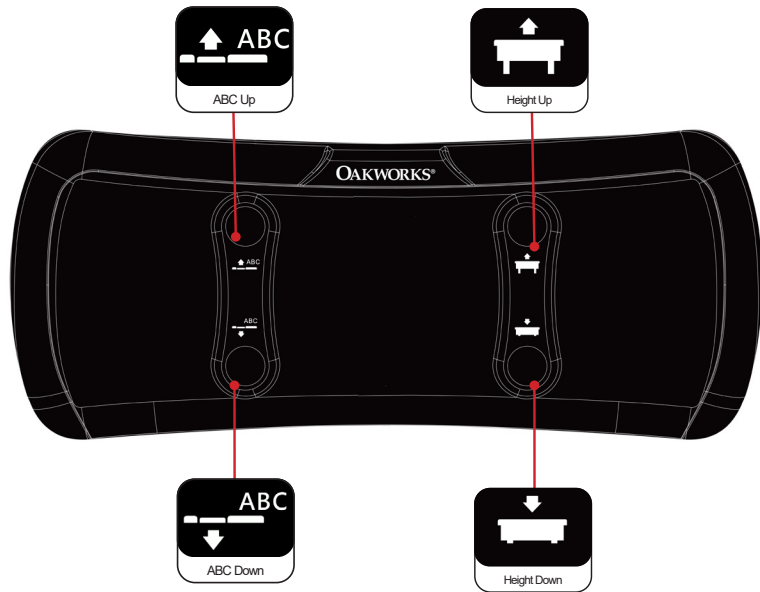

STANDARD FOOT CONTROL

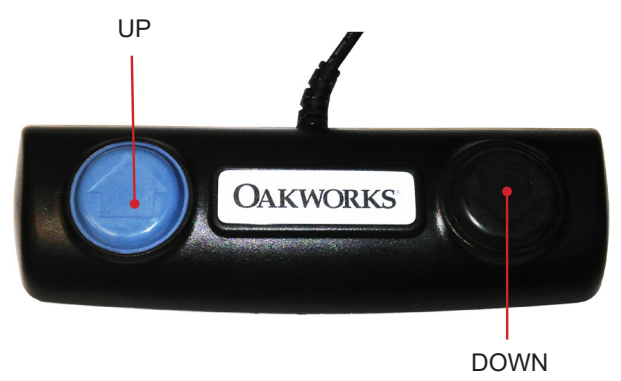

ABC SYSTEM UP



ABC SYSTEM DOWN



OPTIONAL HAND CONTROL

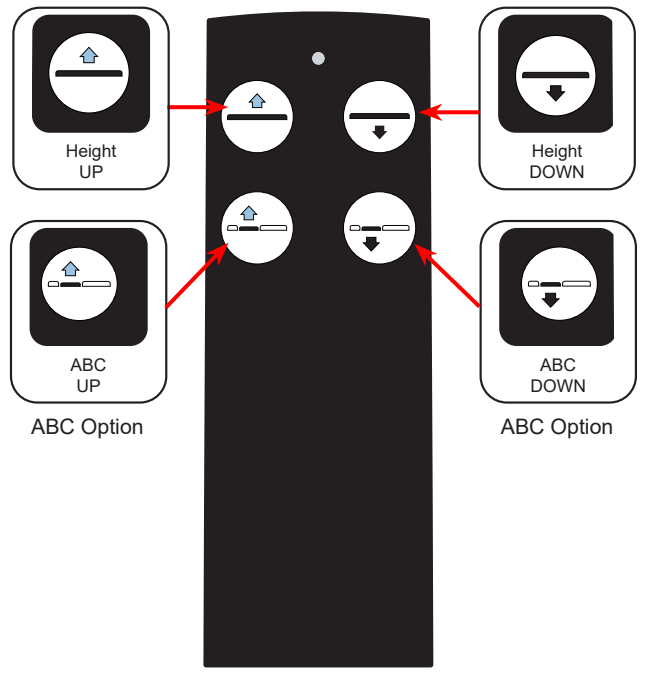

PRODUCT DESCRIPTION

Clinician Electric-Hydraulic Lift-Assist Backrest



STANDARD SPECIFICATIONS	
Motion 1	Powered 26"-36" (66-91 cm.) Height Range
Motion 2	Manual 0-80° Backrest
Foot Control	Height Range
Table Voltage Options	120V/60Hz - 230V/50Hz
Table Capacity	500 lbs. (227 kg.) (client and accessories)
Widths	29" (74 cm.), 31" (79 cm.), or 33" (84 cm.)
Length	73" (185 cm.)
Padding	4" (10 cm.) or 6" (15 cm.) Aerocel Foam™
Table Weight*	150 lbs. (68 kg)

OPTIONS
Adjustable Breast Comfort (ABC) System
Wood Finishes
Storage Cabinet w/Sliding Doors
Hand Control
Integrated Heated Top
ACCESSORIES
QuickLock Face Rest
Boiance Shelf Support

PRODUCT DESCRIPTION

CONTROL OPERATIONS - LIFT ASSIST BACKREST

CAUTION Do not sit on backrest section. The hood area under the backrest top is not designed for storage. DO NOT use this area for holding anything. Damage can occur to the table.

The Clinician Electric-Hydraulic Lift-Assist Backrest Tables offer height and optional ABC positioning with electronic ease. Operate the foot control and/or optional hand control as shown below to raise or lower the height or optional ABC function of the table.

FOOT CONTROL WITH ABC

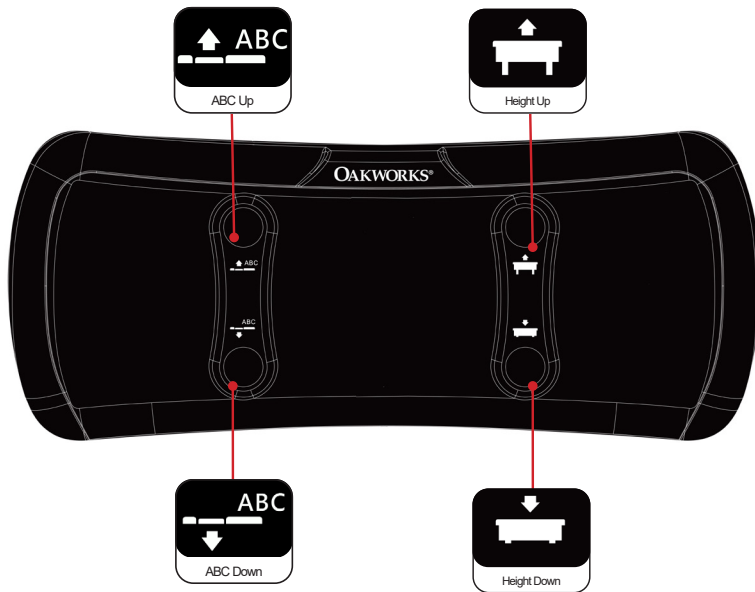

STANDARD FOOT CONTROL

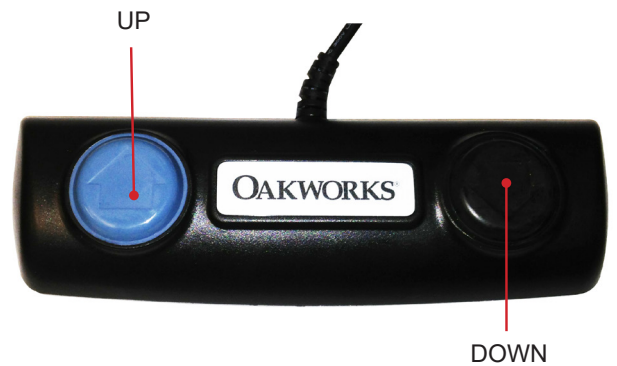

OPTIONAL HAND CONTROL

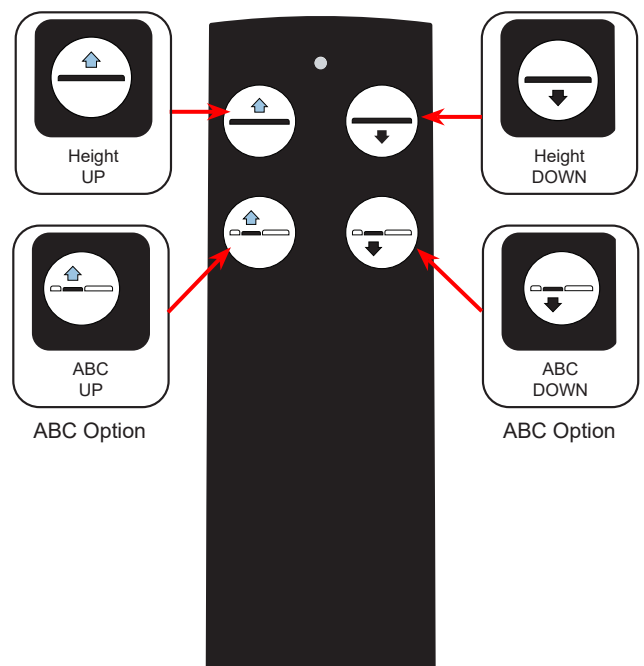
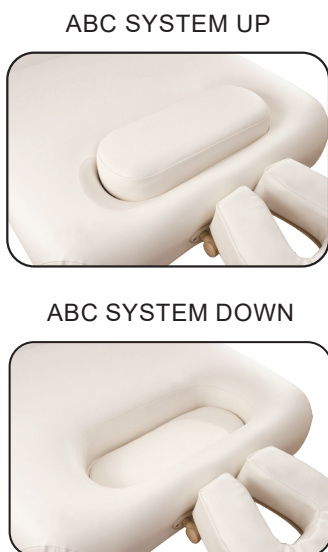

PRODUCT DESCRIPTION

Clinician Electric-Hydraulic Flat Top



STANDARD SPECIFICATIONS	
Motion 1	Powered 26"-36" (66-91 cm.) Height Range
Foot Control	Height Range
Table Voltage Options	120V/60Hz - 230V/50Hz
Table Capacity	500 lbs. (227 kg.) (client and accessories)
Widths	29" (74 cm.), 31" (79 cm.), or 33" (84 cm.)
Length	73" (185 cm.)
Padding	4" (10 cm.) or 6" (15 cm.) Aerocel Foam™
Table Weight*	145 lbs. (66 kg)

OPTIONS
Adjustable Breast Comfort (ABC) System
Wood Finishes
Storage Cabinet w/Sliding Doors
Hand Control
Integrated Heated Top
ACCESSORIES
QuickLock Face Rest
Boiance Shelf Support

For electrical specs, see Specifications section.

PRODUCT DESCRIPTION

CONTROL OPERATIONS - FLAT TOP

The Clinician Electric-Hydraulic Flat Top Tables offer height and optional ABC positioning with electronic ease. Operate the foot control and/or optional hand control as shown below to raise or lower the height or optional ABC function of the table.

FOOT CONTROL WITH ABC

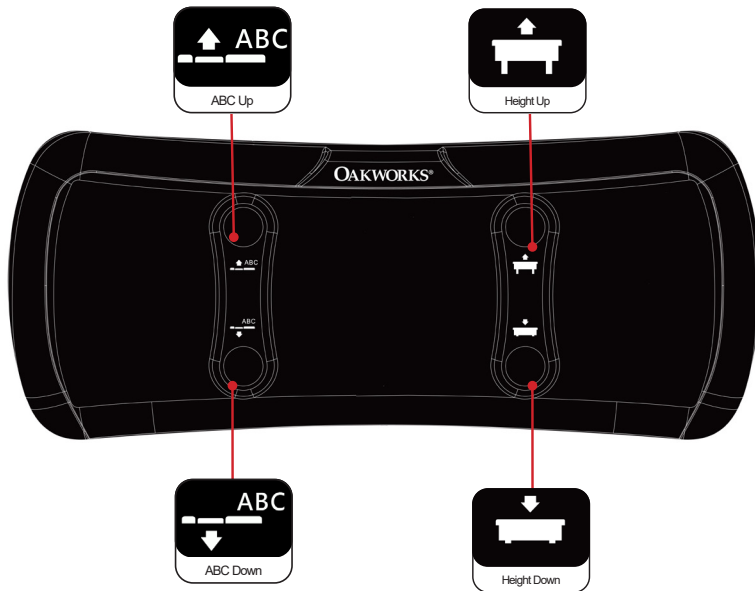

STANDARD FOOT CONTROL

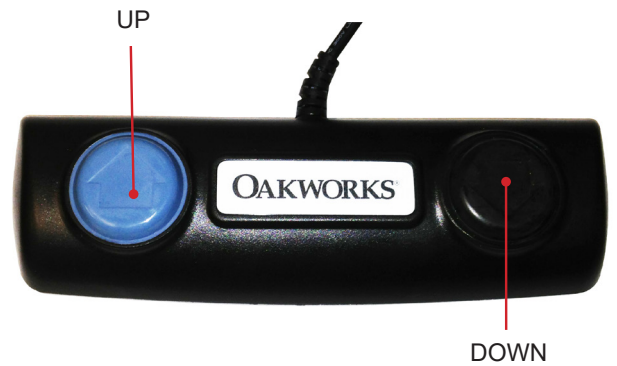

OPTIONAL HAND CONTROL

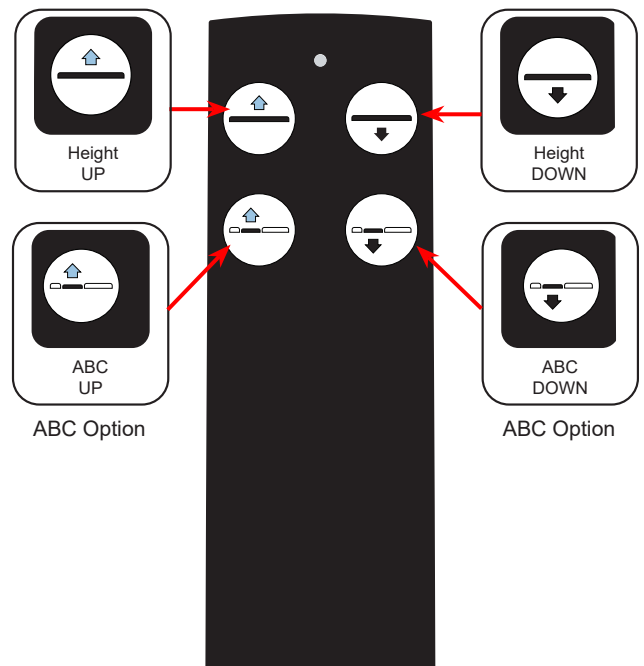
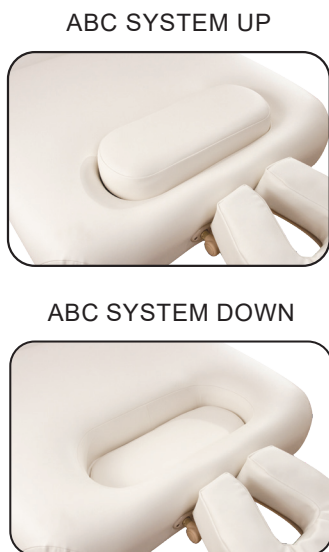

PRODUCT DESCRIPTION

Clinician Manual-Hydraulic Lift-Assist Salon



STANDARD SPECIFICATIONS

Motion 1	Manual 26"-36" (66-91 cm.) Height Range
Motion 2	Manual 0-80° Backrest
Motion 3	Manual 0-30° Leg Rest
Table Voltage Options	120V/60Hz - 230V/50Hz
Table Capacity	500 lbs. (227 kg.) (client and accessories)
Widths	29" (74 cm.), 31" (79 cm.), or 33" (84 cm.)
Length	73" (185 cm.)
Padding	4" (10 cm.) or 6" (15 cm.) Aerocel Foam™
Table Weight*	140 lbs. (63.5 kg)

OPTIONS

Wood Finishes
Storage Cabinet w/Sliding Doors
Integrated Heated Top

ACCESSORIES

QuickLock Face Rest
Boiance Shelf Support
Side Arm Rests

PRODUCT DESCRIPTION

Clinician Manual-Hydraulic Lift-Assist Backrest



STANDARD SPECIFICATIONS	
Motion 1	Manual 26"-36" (66-91 cm.) Height Range
Motion 2	Manual 0-80° Backrest
Table Voltage Options	120V/60Hz - 230V/50Hz
Table Capacity	500 lbs. (227 kg.) (client and accessories)
Widths	29" (74 cm.), 31" (79 cm.), or 33" (84 cm.)
Length	73" (185 cm.)
Padding	4" (10 cm.) or 6" (15 cm.) Aerocel Foam™
Table Weight*	135 lbs. (61 kg)

OPTIONS
Wood Finishes
Storage Cabinet w/Sliding Doors
Integrated Heated Top
ACCESSORIES
QuickLock Face Rest
Boiance Shelf Support

PRODUCT DESCRIPTION

Clinician Manual-Hydraulic Flat Top



STANDARD SPECIFICATIONS

Motion 1	Manual 26"-36" (66-91 cm.) Height Range
Table Voltage Options	120V/60Hz - 230V/50Hz
Table Capacity	500 lbs. (227 kg.) (client and accessories)
Widths	29" (74 cm.), 31" (79 cm.), or 33" (84 cm.)
Length	73" (185 cm.)
Padding	4" (10 cm.) or 6" (15 cm.) Aerocel Foam™
Table Weight*	130 lbs. (59 kg)

OPTIONS

Wood Finishes
Storage Cabinet w/Sliding Doors
Integrated Heated Top

ACCESSORIES

QuickLock Face Rest
Boiance Shelf Support

DIRECTIONS FOR USE

HYDRAULIC DAILY CYCLING

The Clinician Series uses hydraulics and hydraulic fluids to adjust the table height. Maintaining the quiet operation of your table requires that you fully cycle your table (up & down) twice per day. Cycling of the table will maintain the lubrication within the hydraulic cylinders for continued smooth and quiet operation. When not possible, we recommend that you cycle the table (up & down) four times at least once per week.

MANUAL-HYDRAULIC HEIGHT ADJUSTMENT

To raise the table, unfold the crank handle until it locks into place. Turn the crank clockwise to raise the table to the desired height. To lower the table, turn the handle counter-clockwise.

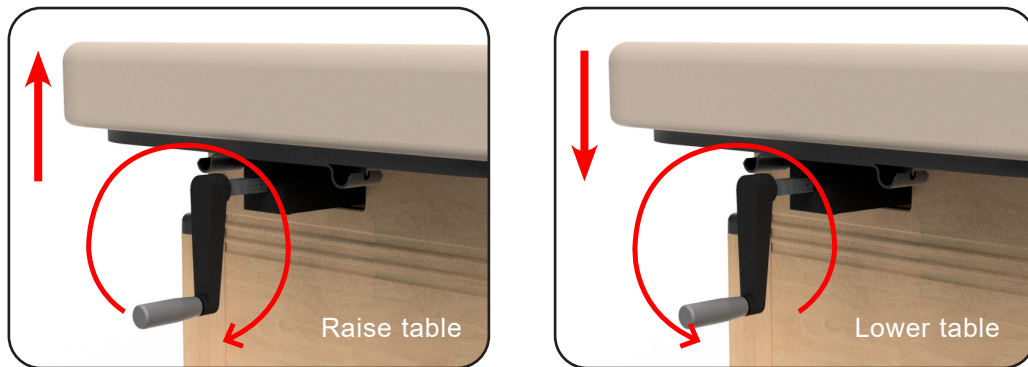

To fold handle out of the way, rotate until the handle is at its lowest point, then pull out slightly. Fold down under the table.

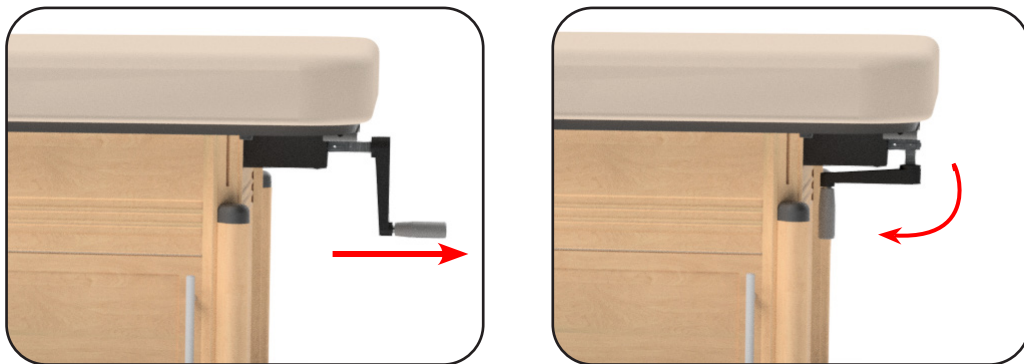

Note: Folding the handle when it is not at its lowest point can damage the area around the handle.

DIRECTIONS FOR USE

LIFT-ASSIST BACKREST ADJUSTMENT

 **CAUTION** Do not sit on the backrest section.



TO RAISE THE BACKREST:

Raise the back rest by pressing the lever under the head section and lifting up to the desired height. It is recommended that clients take some of their weight off the back rest while you lift.



TO LOWER THE BACK REST:

Press the lever under the head section and push the back rest down.

TO CHANGE POSITION OF THE BACKREST LEVER:

The backrest lever can be moved to the opposite side of the back rest by removing the screws and relocating the hand lever to the opposite side of the top into the four pre-drilled holes.

LIFT-ASSIST LEG REST ADJUSTMENT



TO RAISE THE LEG REST:

Raise the leg rest by pulling the lever on the side of the leg section and raise to the desired height. It is recommended that clients take some of their weight of the leg rest while you lift.



TO LOWER THE LEG REST:

Pull the lever on the side of the leg section and push the leg section down. Release the lever once the leg rest is at its desired location and the leg section will stay in place.

TO CHANGE POSITION OF THE LEG REST LEVER:

The leg rest lever can be moved to the opposite side of the table. First, remove the screws from the lever and replace the screws. Move the lever to the opposite side of the table. Remove the screws that are there and mount the lever.

DIRECTIONS FOR USE

MOVING THE TABLE



CAUTION

Before moving the table, disconnect the power cord from the power outlet. The table weighs as much as 155 lbs. (70 kg.) Never lift the table by grasping the table top. You could damage the table and the electronics that run the tabletop. Two people are required to move the table safely. Do not use the table to transport a client.

When moving the table, place one person at each end of the table. Have each person firmly grasp the base at the bottom and lift the table. Be aware and use proper, safe procedures for moving a table of this size to prevent injury to yourself or the table. We strongly recommend that a flatbed dolly be used that can hold the entire table when moving the table long distances.



At low height range



Grasp at base end rail

TABLE LEVELING INSTRUCTIONS

1. Place the table in the location where you plan to use it.
2. Rock the table to determine if it is level with the floor. If the table rocks back and forth at all, the foot that clears the floor when you rock the table will need adjustment.
3. Adjust the Leveler Foot by first loosening the locking nut found just above the rubber Leveler Foot with the 1/2" open-end wrench.
4. Lower the adjustable rubber Leveler Foot until it meets the floor snugly. Tighten the locking nut against the leg of the table with the 1/2" open-end wrench to fix the Leveler Foot in position.
5. Rock the table again to be sure adjustments have stabilized the table. If necessary make any additional adjustments in the same way.



DIRECTIONS FOR USE

REMOVING TOP PAD

The top pad has been designed to be easily removable and replaceable with no tools needed.

IF THE TABLE HAS A HEATED TOP:

Unplug the table from the wall outlet and disconnect the wires circled from the control box located under the platform. Pull the cables through the platform before completely removing the top pad.

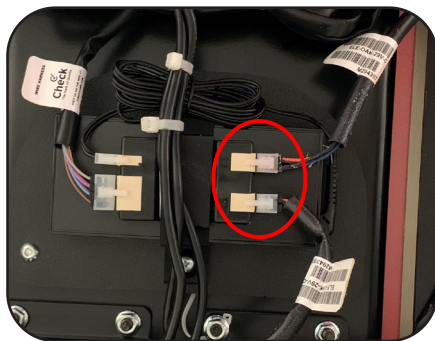

Heated Top Cables

TO REMOVE THE TOP PAD:

The top pad is attached to the platform with 8 thumb screws located below the platform as shown.



Thumb Screw Locations (4 per side)



1. Unscrew the thumb screw clockwise until the thumb screw is completely removed. Repeat for all 8 thumb screws. If the thumbs screws are on too tight, a 3/16" bit can be used.

2. Lift top pad off the platform.

DIRECTIONS FOR USE

ADJUSTABLE BREAST COMFORT (ABC) SYSTEM (OPTION)



CAUTION

- ABC System Weight Limit - 100 lbs. (45 kg.) Do not sit on the ABC System.
- Do not place foreign objects into the ABC System. Only use as intended.
- For safety of your client, use a cloth sheet between the ABC System and your client.

The Oakworks Adjustable Breast Comfort (ABC) System is designed to lower the pressure on breasts and pectoral muscles, allowing the client to relax and create a more comfortable position for their spine. The height of the cushion is easily adjusted up and down in small increments by using the hand control. We recommend that the cushion height be adjusted in the following ways:

****Always start with the cushion top level with the top of the table for Prone or Supine Positioning****

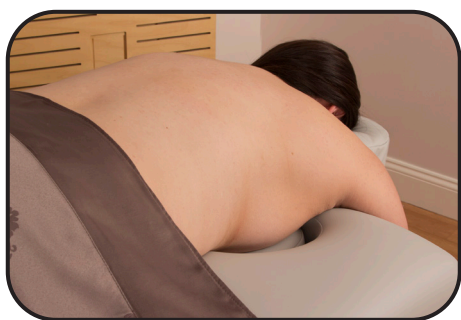

PRONE POSITIONING

In Prone positions, for male or female clients when the face rest is in use, lower the cushion approximately 3/4" at a time (This is approximately 1 second of lowering) and check in with the client regarding their comfort after making the change. Incrementally lower the cushion until the client reports they are comfortable. Sometimes going back up a little will be preferred. This whole process takes no more than 15-20 seconds. After lowering, check headrest position to ensure comfort & support. *NOTE: Breast size is not the only determinate of cushion location. Every person's comfort spot is different, regardless of breast size.*



SUPINE POSITIONING

When turning clients over in the supine position, you may use the cushion to level during or after their change of position. It is not important that the cushion be completely level. As in prone positions, make small changes in height and check in with the client.



HEAD REST USE IN SUPINE

If you are using the head rest in the Supine position, you may use the cushion at relatively high heights to facilitate stretching for short periods of time. It is not recommended that clients experience this position for more than a few minutes.

DIRECTIONS FOR USE

INTEGRATED HEATED TOP (OPTION)

USING THE INTEGRATED HEATED TOP:

The table comes with the option for a fully integrated heated top pad. Simply press the heating indicator located on the right side of the table to the desired heat level. The heat can reach up to 43°C (110°F). The system comes equipped with an 8 hour automatic shutoff.

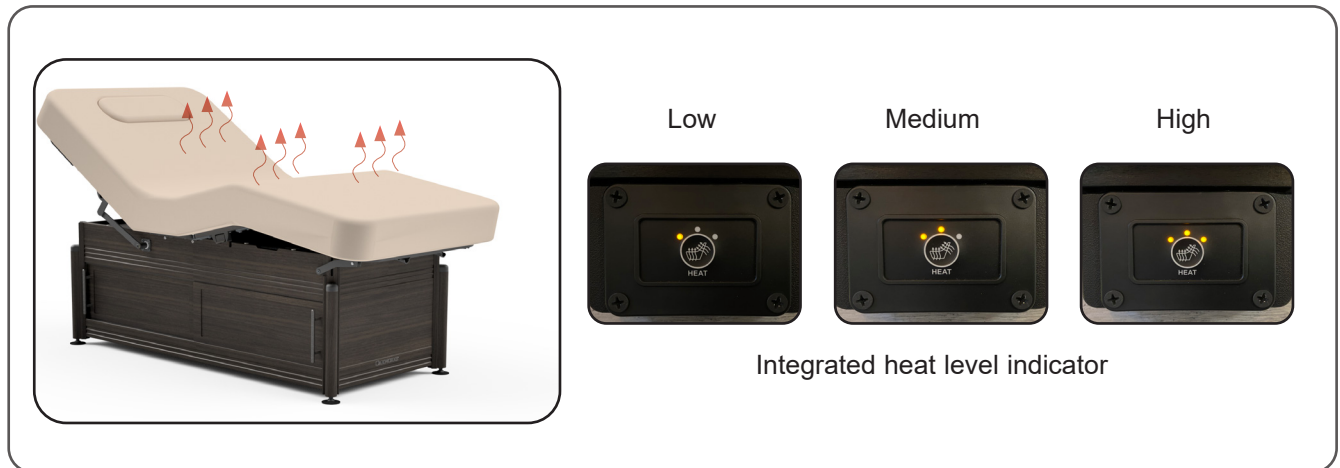

BLINKING LIGHTS

If the controller's heat level indicator lights are blinking, the heating elements are not connected properly and/or damaged. Unplug the table and locate the control box on the underside of the table top. Disconnect the heating element connectors from the control box and reconnect. Plug the power cord back into the wall outlet. Call Customer Service at 717.235.6807 if problem continues.

DIRECTIONS FOR USE

QUICKLOCK FACE REST: (ACCESSORY OPTION)



CAUTION

- QuickLock Face Rest Weight Limit - 25 lbs (11.3 kg)
- Do not put excessive weight or pressure on the Face Rest.
- Excessive pressure can cause premature failure of the Face Rest.

Double articulating action provides nearly limitless positioning options with the QuickLock Face Rest. The adjustable pad takes pressure off sensitive facial areas while providing superb support. The QuickLock Face Rest can be used in both prone and supine positioning and folds out of the way when not in use. Adjustments are made easily by loosening the cam locks, adjusting for height and angle and then locking locks into that position. The table has a bracket at the head of the table for a variety of uses.



ATTACHING QUICKLOCK FACE REST:

When attaching the QuickLock™ Face Rest, slide the frame dowels into the bracket until bullet catches are snapped into place.

To remove the QuickLock™ Face Rest, gently pull the headrest by the dowels until it comes free. Set it safely aside or store it inside the under-table cabinet until needed.

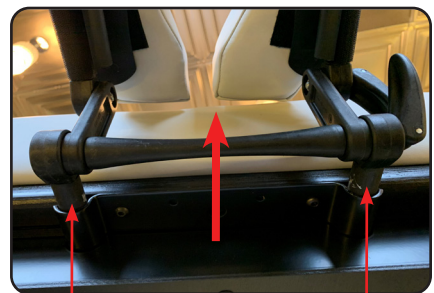

To remove

Pull by dowels

Pull by dowels

TIPS FOR GREAT POSITIONING USING THE QUICKLOCK™ FACE REST:

To use the face rest with your clients supine, rotate the face rest pad so that the thick part of the pad supports your client's cervical region. Adjusting the height and angle of the face rest gives your clients perfectly comfortable support.

The face pad is flexible so that you can bring the open ends together or spread them apart to achieve the most comfortable support for any size face. To avoid your client's chin from hitting the spacebar, make sure the pad is narrow enough to support their whole face.

For appropriate cervical flexion, use the cam locks to adjust the downward angle of the face rest, making sure that the surface of the face rest pad at the chin is not lower than the surface of the table.

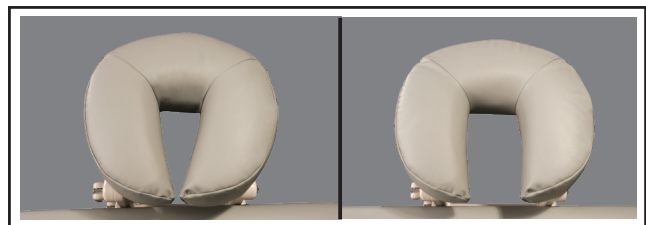

DIRECTIONS FOR USE

ADJUSTABLE SIDE ARM RESTS (ACCESSORY OPTION - SALON ONLY)



CAUTION

- Do not use the arm rest for client support during the mounting or dismounting of the chair.
- The arm rest is not designed to support the client's weight.

TO INSTALL THE ARM RESTS:

The Arm Rests adjust automatically as the back rest moves to remain parallel to the floor.



1. Insert end of arm rest into backrest hole while holding the arm rest at a 60° angle to the backrest.
2. Push end all the way into the hole and drop the arm rest into the horizontal position. Pull outward to make sure the arm rest is secure.

TO LEVEL THE ARM RESTS:

The Arm Rest height is adjusted at the factory for each table. If the armrest starts to sag with repeated use, follow the steps below to readjust.

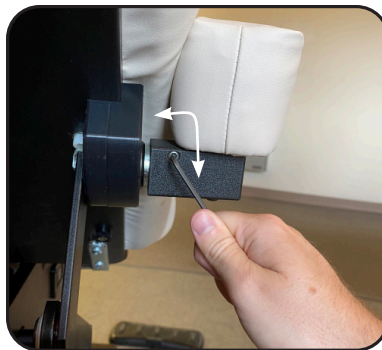
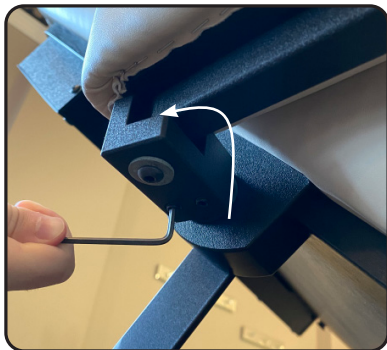

1. Loosen the bottom 2 set screws.
2. Turn the side set screw (clockwise to raise or counter-clockwise to lower) while adjusting the arm rest. Lift the arm rest slightly when doing this adjustment to reduce the weight.
3. Tighten the two bottom set screws to lock the position.

CLEANING & DISINFECTION

RECOMMENDED CLEANERS/DISINFECTANTS



DANGER

To reduce the risk of electric shock:

- Always unplug this furnishing from the electrical outlet before cleaning.

Reference the Recommended Cleaners and Disinfectant list (MMINML0008-EN) that came with the table. This information can also be found at www.shop.spatables.com under product information.

All cleaners and disinfectants have the ability to degrade the upholstery to some extent. However, following the recommended cleaner and disinfectant list and cleaning process will provide the best care for your table and support a long product life.

Oakworks recommends a prepackaged wipe for cleaners/disinfectants to ensure best distribution of disinfectant for the required kill time, without leaving excess residue and/or overexposing components therefore minimizing the potential for damage to materials. Please read and follow disinfectants manufacturers' directions for cleaning and disinfection.

Oakworks does NOT recommend the use of cleaners/disinfectants containing Hydrogen Peroxide, Acetic Acid, or Phenolics. These chemicals can cause damage to the appearance and/or material integrity of various components. Also, while the recommended cleaners/disinfectants list includes products containing Quaternary Ammonium compounds ("quats"), not all products containing quats are approved for use. Some contain additional detergents and/or surfactants which can damage some materials.

Use of non-approved cleaners or disinfectants may lead to damage to upholstery and other materials found on the table and will void the warranty.

CLEANING PROCESS

Follow the cleaners/disinfectant manufacturers' directions for use. Please note that cleaning and disinfecting an Oakworks table is a two part process. First it must be cleaned of any visible soil, then it can be disinfected. Oakworks recommends that the table be positioned in the flat position during the cleaning process. Please follow this procedure for best results:

1. Using an approved cleaner or mild liquid soap and water, clean any visible soil off of the table, working from the top to the bottom of the table. It is recommended that the upholstery be cleaned at least once a week to prevent disinfectant build up.
2. Rinse with clean water and dry with a clean cloth or towel.
3. Using an approved disinfectant, thoroughly disinfect all surfaces of the tabletop and any high-contact areas such as handles, handsets, etc., making sure they remain wet for the disinfectant manufacturer's recommended contact time. Do not allow disinfectant to pool on the upholstery after the recommended contact time.
4. Wipe off any excess liquid with a cloth or towel and clean water.
5. Dry all surfaces with a clean cloth or towel.

Avoid using writing instruments or other similar instruments around the upholstery as it can cause permanent staining. If this does occur, do not wipe with an alcohol based cleaner. Instead, blot the stain with a clean cloth/ paper towel. Use a recommended cleaner or disinfectant to remove the stain. Follow this with a rinse of clean water.

INSPECTIONS / WARRANTY

INSPECTIONS

RECOMMENDED REGULAR INSPECTIONS (monthly or local standard)

- Check for damage to the power, hand control(s) and foot control(s) on all cables.
- Visually inspect components for obvious damage that could cause problems during operation.

RECOMMENDED PERIODIC INSPECTIONS (yearly or local standard)

- Check for damage to the power, hands control and foot control cables and all visible wiring.
- Visually inspect components for obvious damage that could cause problems during operation.
- Check all mechanical functions using the hand control. Repeat using the foot control. Check for abnormal noises.
- Check that all fasteners are present and fastened securely.
- Check table grounding.
- Clean unusual buildup of dirt on the table and/or parts of the table not normally cleaned on a regular basis.
- Check for tears or cracks in the upholstery.

WARRANTY

View complete warranty details at www.shop.spatables.com under the Information tab "Warranty and Return Policy".

MODEL NUMBER & SERIAL NUMBER

MODEL & SERIAL NUMBERS



The model number and serial number are located on the underside of the foot section of the table top

Model Number

Serial Number

Hydraulic Lift Tables



16796025 CFSA4LF1T410USXXPW
Ser#: CFK123456 06/03/2020 Order#:785461
Clinician Electric-Hydraulic LA Salon 1/T/4/11/US/XX/PW
TT Stone Notes: XXX

120V~ 60Hz
12.0 Amps Max

 CONFORMS TO:
UL STD 962
Certified to
CAN/CSA STD
C22.2 No. 68-09

Intertek
3034177

220/230V~ 50Hz
6.3 Amps Max

EC REP 

EMERGO EUROPE
Prinsessegracht 201, 2414 AP,
The Hague, The Netherlands



OAKWORKS[®], INC.
923 East Wellspring Rd.
New Freedom, PA 17349 USA
Phone: 717-235-6807
www.oakworks.com

made in the USA
with US & imported parts





Duty Cycle:
MAX 2 minutes ON
18 minutes OFF

Part No. CN62188 - Rev. 1

Model and Serial numbers always start with a letter.

SPECIFICATIONS

TABLE DIMENSION

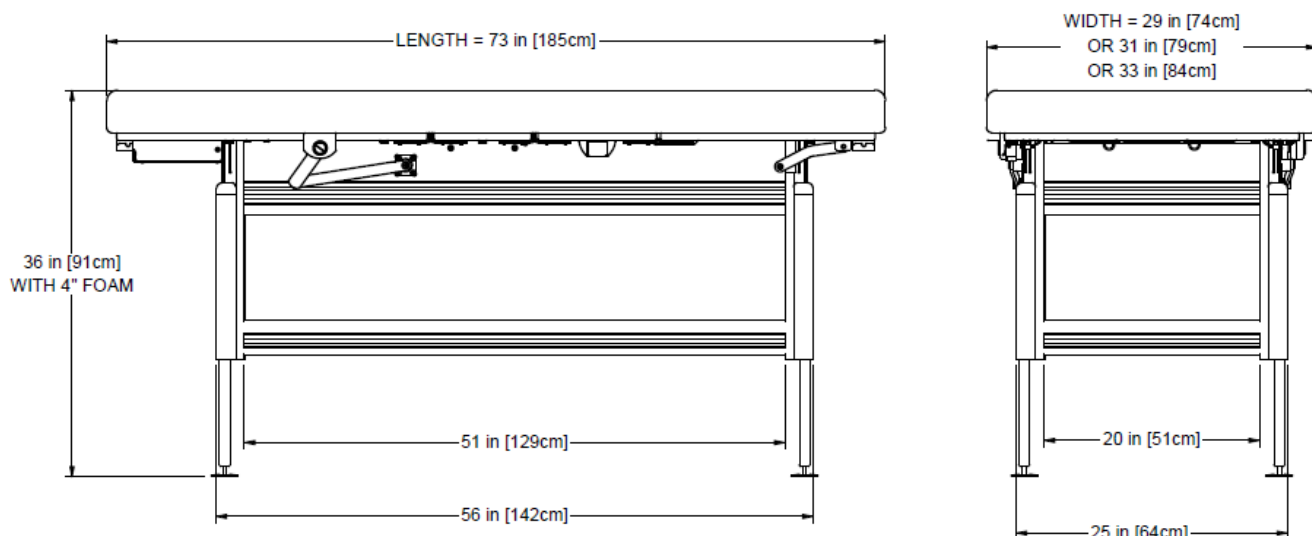

CABINET DIMENSIONS

Total Inside Dimensions:	53" L x 21" W x 10" H	135cm L x 53cm W x 25cm H
Opening Dimensions: Head End	26" L x 10" H	65cm L x 25cm H
Opening Dimensions: Foot End	24" L x 10" H	61cm L x 25cm H

ENVIRONMENTAL CONDITIONS

Conditions	Temperature	Humidity	Atmospheric Pressure
Normal Use	50° (10°C) to 104° (40°C)	20% to 60% RH	98 to 105 kPa
Storage & Transport	-20° (-29°C) to 135° (57°C)	20% to 95% RH	98 to 105 kPa

ELECTRICAL SPECIFICATIONS

Designed for:	North America	Europe
Input Service	120V~ 60Hz, 12.0 Amps	220V~ 60Hz, 6.3 Amps
Electric Shock Protection	Class I Equipment	
Mode of Operation	10% Duty Cycle; MAX 2 minutes ON / 18 minutes off	

THIS PAGE IS INTENTIONALLY LEFT BLANK

USER MANUAL

OAKWORKS®

Clinician Hydraulic

CONTACT INFORMATION:



OAKWORKS® Inc.

923 East Wellspring Road
New Freedom, PA USA 17349

Phone: 717.235.6807

FAX: 717.235.6798

www.oakworks.com



Emergo Europe
Westervoortsedijk 60
6827 AT Arnhem
The Netherlands



Intertek

3034177

CONFORMS TO:
UL STD 962
Certified to CAN/CSA STD C22.2 #68

Original Instructions

Manual Part Number: SPA-RA-PM-152

Revision level: 10

Revision Date: 04/09/2024

English, Printed in USA



OAKWORKS® Spa